

 **SONOR**[®]
Drums



Drums
Hardware 2016
Accessories

sonor.com



*Excellent
engineering
& Craftmanship*
Made in Germany since 1875

Christoph Schneider (Bammstein), Photo by Olaf Heine

Content

SONOR History	02
SQ ² Series	04
Vintage Series	24
ProLite Series	32
Select Force Series	44
Essential Force Series	48
Smart Force Xtend Series	52
Special Edition Series	54
Artist Series Snare Drums	58
Signature Series Snare Drums	60
Phonic Re-Issue Snare Drums	63
ProLite Series Snare Drums	64
Perfect Balance Bass Drum Pedal	68
Giant Step Bass Drum Pedals	70
600 / 400 Hardware Bass Drum Pedals	72
Hi-Hat Stands	72
Drum Thrones	73
Cymbal Stands / Double Cymbal Stands / Boom Arms	74
Snare Stands / Combination Stands / Tom Stands	76
Basic Arm System Hardware / Multi Holder	78
Tom Holder	80
Hardware Sets	81
Accessories / Soundwires / Drumheads	82
ARMONI Cymbals	84



www.youtube.com/SonorDrumTube



www.facebook.com/sonordrums



www.twitter.com/sonor_drums

© SONOR GmbH | Catalog DR 01012016 E
Product Design: Thomas Barth, Karl-Heinz Menzel, Philipp Rabe, Werner Saßmannshausen, Frank Boestfleisch, David Schulz
Product Photography: Martin Kreutter, Marburg, Shansi, Beijing and SONOR, Bad Berleburg, Aue
Cover Photo: Jojo Mayer by James Cumpsty - Concept and Graphic Design: Krause & Krause, Marburg - Text Concept: Thomas Barth, Frank Boestfleisch, David Schulz, Gary Ingrassia
SONOR reserves the right to update or change its products without advance notice. Wood is a natural product, which can cause slight alterations in color and grain. Print reproduction of Drum designs and finishes can vary depending on color density and general print quality.

www.sonor.com



1875 - 1900

In 1875 Johannes Link, a trained wood turner and tanner, started a small workshop for simple military drums and drum heads in Weißenfels an der Saale in East Germany. From these modest beginnings developed a flourishing business, which at the turn of the century already offered a comprehensive range of percussion instruments.



Johannes Link

1900 - 1925

In 1900, SONOR introduced its first single bass drum pedal. A simple mechanism built under simple circumstances, still far from what was introduced over a century later under the name „Giant Step“ or „Perfect Balance“. In 1907 the SONOR trademark was registered with the Imperial Patent Office. In 1914 Otto Link, son of Johannes Link, assumed management of the company after the passing of the founding father. Around 1925, celebrating its 50th anniversary, SONOR had 145 employees and was one of the largest businesses of its kind.

Otto Link later became Consul to Sweden and a personal friend of King Gustav V. Due to this connection, the Link Company became the exclusive supplier to the Swedish royal house. This relationship was the base for SONOR's rebirth in Aue after WWII.



Otto Link

1925 - 1946

More innovations were being introduced, such as the first double pedal „Duplex“ in 1927. The first Snare Drum with multi 3-way strainer, a novelty for its time, was introduced to the market in 1930. Military contracts kept the company busy during the war time, but the emerging war results in the collapse of the golden Weißenfels era.



1946 - 1960

At the close of World War II, Otto Link's son Horst returned from military service to begin work at the family business. However, when the Russian occupation forces in East Germany began arresting the returning German soldiers and sending them to Siberia, Horst fled to Aue, in the British-occupied section of Germany. There, he established a tannery in a rundown army barracks and began making drum heads. Starting a drum company in Aue was no small feat. The area was largely populated by dairy farmers, who were unskilled for his company's needs. Reflecting on this period, Horst Link said, „The lack of skilled labor initially made our job very difficult. We had to train everyone from scratch. But over the years, having located in Aue has helped us immeasurably. We have a stable and loyal work force that we could never duplicate in a larger city.“

In 1952, the first drum kit with concert toms was introduced. At the same time, SONOR introduced the famous „script logo“ trademark which embellished all drums from the early teardrop era for nearly a decade.



1960 - 1990

In 1961, the first SONOR „Mallet“ logo was introduced, created by famous designer Otl Aicher. The Mallets have been an inherent part of the design not only of the logo trademark, but also in product design until today. The following decades marked a striking number of milestones in the company's ongoing journey of innovation and craftsmanship. 1973 saw the introduction of Vertical Grain Drums on the „Champion“ Series. In 1975 the famous Phonic Series as well as Champion Acrylic drum sets were introduced. In the same year, the 45 degree bearing edge was introduced and used on all series from then on. More notable series from this era, and highly sought-after collector's items are Signature (1982), Phonic Plus (1983), Lite (1984) and HiLite (1986). In 1993 the Jet Set (based on the Signature Series), with 24k gold plated hardware, being the most expensive drums for its time, creates international buzz. SONOR continues to modernize and yet like Henry Ford 60 years earlier, makes most components in-house. Raw materials come in, finished products go out. This tradition continues into the early 1990's.



1990 - today

Taking drum manufacturing to the next level: the era of customization is kicked off. The Designer Series, introduced in 1994, is the first series that offers multiple choices of shell construction, drum sizes, finishes, and hardware. The idea was taken to a new level and perfected with the launch of SQ² drums in 2006. One kit build at one time, no one like the other, each drum a masterpiece of handcraftsmanship and as unique as a fingerprint.

In 2000, SONOR introduced the Delite series which set the stage for its successor, the ProLite Series (2012). Like in all other decades, remarkable technical innovations in the hardware sector go hand in hand with some of the finest drums available: Giant Step pedals in 2001, and Perfect Balance Pedal designed by Jojo Mayer in 2012.

We are looking back at a history like no other in the industry of drum manufacturing. Celebrating our 140th anniversary in 2015, we've introduced one of the globally most anticipated products: the Vintage Series, awarded „Best In Show“ at the 2015 Winter NAMM Show. We literally hit the reset button and (re-)introduced the analogue sound into a digital world, taking the best from the past in combination with our experience in modern manufacturing technology „Made in Germany“.



The SQ² Drum System represents SONOR's extensive know-how in drum making and sound design. Building upon more than 140 years of manufacturing experience this range of custom instruments offers the ultimate in SONOR craftsmanship. It is the flagship within the SONOR drum program.

As a leading manufacturer of highest quality drums and percussion instruments SONOR has always set new standards and opened doors to new levels of perfection. The SONOR Signature series, first introduced in the mid-80s is one example. Later the SONOR Designer series introduced true custom design to the drumming community. Now with SQ² SONOR again demonstrates its innovative power and uncompromising dedication to quality.

SQ² is more than a drum series. It is a concept both of making drums and selecting drums. With an almost unlimited variety of shell - size - finish combinations, SQ² is the most individualized series in SONOR's history, offering the most unique drums you have ever dreamed of playing. It allows you to speak with your personal musical voice. It is your signature in sound.

Start building your dream here:

WWW.SQ2-DRUMSYSTEM.COM

American Walnut

SQ² Set in American Walnut with Gold Hardware

Setup: Bass Drum 22" x 18" / Tom Toms 8" x 7", 10" x 8", 12" x 9" /
Floor Toms 14" x 13", 16" x 15" / Snare Drum 14" x 7"

UPID 144612911584-1

Ruby Red



SQ² Set in Ruby Red with Black Chrome Hardware
Setup: Bass Drum 22" x 19" (2x) / Tom Toms 10" x 8", 12" x 9" / Floor Toms 16" x 15", 18" x 16" / Snare Drum 13" x 6"
UPID 135575516916-1

*Blue
Tribal*

SQ² Set in Blue Tribal
with Chrome Hardware

Setup: Bass Drum 22" x 15" /
Tom Toms 8" x 7", 10" x 8", 12" x 9" /
Floor Toms 14" x 13", 16" x 15" /
Snare Drum 14" x 5"

UPID 135575352611-1

from our hands

Start your own dream today. Simply log on to www.sq2-drumsystem.com and let the drum builder lead you through the configuration process. To order your personal SQ² drums, simply submit the UPID number of your configuration to your local SONOR dealer (a list of authorized dealers can be found in the SQ² configurator by clicking 'SQ² dealer').

As soon as we receive the order from your chosen local dealer, your individual UPID number will be transferred into our database system and forwarded onto the SONOR production department!

Ever wanted to learn how your drums are being made? Let us show you the steps from collecting the finest raw materials to final assembling - all done by master craftsmen!

SONOR selects only the finest wood from environmental friendly sources. All SQ² woods are handpicked only from leading veneer suppliers worldwide.

OPTIMUM SHELL MEASUREMENT (OSM)

SONOR implements a slightly narrow outside shell measurement for optimized head contact. This is a SONOR specialty, resulting in excellent tone, better sustains and controlled decay.

CROSS LAMINATED TENSION FREE PROCESS (CLTF)

SONOR cross-laminates shells for superior stability, sonically enhanced resonance and spectacular tone. The CLTF process is a result of years of research by SONOR craftsmen. All shells are measured and precisely cut to perfection.

45 DEGREE BEARING EDGE

SONOR drums feature a 45 degree bearing edge, designed and introduced by SONOR in 1975, which is an important component of the signature SONOR sound.



to yours

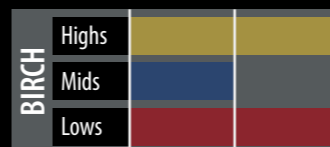

Scandinavian Birch has an aggressive, distinctive tone with tremendous projection. Providing low and high frequency clarity with a smooth balanced mid range.

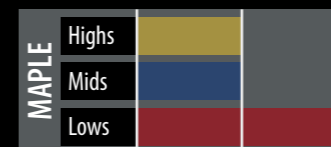

North American Maple offers a mellow, warm and very balanced full tone providing low frequency punch and a mixed balance of mids and highs.

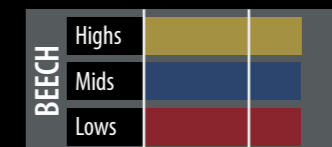

German Beech wood offers a full, warm tone with evenly balanced lows, mids and highs. Tremendous projection, tone and dynamics.

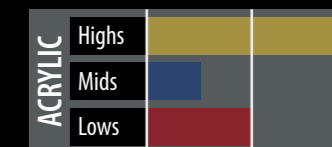

German Acrylic has a full-bodied tone with great presence and powerful dynamics. Accentuated highs and lows are more dominant with reduced mid range frequencies.

Shell construction	Bass Drum / Gong Tom			Snare Drum / Tom Tom / Floor Tom		
	Plies	Veneer	Dynamic Edge	Plies	Veneer	Dynamic Edge
Vintage shell lacquered	3 (6 mm)*		1 (2 mm)*	2 (4 mm)*		1 (2 mm)*
Vintage shell with outer veneer	2 (4 mm)*	1 (2 mm)*	1 (2 mm)*	1 (2 mm)*	1 (2 mm)*	1 (2 mm)*
Thin shell lacquered	3 (6 mm)*			2 (4 mm)* + 1 (1 mm)*		
Thin shell with outer veneer	2 (4 mm)*	1 (2 mm)*		1 (2 mm)* + 1 (1 mm)*	1 (2 mm)*	
Thin shell with inner & outer veneer	1 (2 mm)*	2 (4 mm)*		1 (1 mm)*	2 (4 mm)*	
Medium shell lacquered	3 (6 mm)*			3 (6 mm)*		
Medium shell with outer veneer	2 (4 mm)*	1 (2 mm)*		2 (4 mm)*	1 (2 mm)*	
Medium shell with inner & outer veneer	1 (2 mm)*	2 (4 mm)*		1 (2 mm)*	2 (4 mm)*	
Heavy shell lacquered	4 (8 mm)*			4 (8 mm)*		
Heavy shell with outer veneer	3 (6 mm)*	1 (2 mm)*		3 (6 mm)*	1 (2 mm)*	
Heavy shell with inner & outer veneer	2 (4 mm)*	2 (4 mm)*		2 (4 mm)*	2 (4 mm)*	
Acrylic shell	1 (8 mm)*			1 (6 mm)*		



45 degree bearing edge

Mountain *Burl*



SQ2 Set in Mountain Burl with Chrome Hardware

Setup: Bass Drum 18" x 14" / Tom Tom 12" x 8" /
Floor Tom 14" x 14" / Snare Drum 14" x 5"

UPID 144612754965-1



Smoked Larch

SQ2 Set in Smoked Larch with Chrome Hardware

Setup: Bass Drum 22" x 18" / Tom Toms 10" x 8", 12" x 9" /
Floor Toms 14" x 14", 16" x 16" / Snare Drum 14" x 7"

UPID 144612856864-1

every drum set

as unique
as YOUR
fingerprint

SONOR was the first company to introduce and use spectacular vertical veneers on drums and this has become a trademark of the company. Wood is a naturally growing product, diverse and unique in its pattern and beauty. Vertical veneers are selected, set by hand and matched for your drum in-house by master craftsmen. Each veneer sheet is one of a kind and makes each drum unique like your personal fingerprint.



Special SONOR lacquer formula is used to benefit the grains as best as possible. SONOR features a rotating drying process for perfect surfaces without lacquer drips. SONOR shells are hand lacquered – 5 lacquering steps per shell. All shells are hand sanded and hand buffed – 7 times per shell. This extremely detailed process results in superior brilliance on SONOR's lacquered shells.

FEATURES THAT MATTER

Anything mounted to an SQ² drum has to resemble the extremely high esthetic qualities of this system. Therefore SONOR offers three types of metal finishing – 24k gold, chrome and ruthenium (black plated).



The patented **ADVANCED PROJECTION SYSTEM (APS)** prevents direct contact between wood and metal, and supports the powerful SONOR sustain.



The **TOTAL ACOUSTIC RESONANCE (T.A.R.)** mounting system - vibration free mounting results in pure tone and warm sustain.

Enhanced by the total acoustic resonance and advanced projection system, your drum enjoys sonic freedom and stays mechanically stable, resulting in beautiful tone and unmatched projection. The patented Acoustigate allows you to fine-tune your sonic fingerprint by turning a dial, it has never been easier.



DUAL GLIDE SYSTEM

The **DUAL GLIDE SYSTEM** represents a new snare strainer mechanism and is now incorporated into the SQ² drum system.

The new strainer mechanism features a technically perfected snare wire engage-and-release system, along with great adjustability and a solid look and feel. "Dual Glide System" refers to the precise and smooth action, which in turn eliminates any un-wanted sounds when the snare wires are placed in "on" or "off" position. Both the strainer and butt sides are equipped with a fast-release snare wire detach function, allowing the drummer to change the resonant head without having to loosen and adjust the snare wires. A fine-tune adjustment knob is employed on both sides.

To **VIEW AND ALTER AN SQ² CONFIGURATION**, go to the SQ² Configurator website and click 'find unique print id (UPID)'. Enter your UPID number and click 'view configuration'. A PDF file opens showing the related configuration. Go back to the Configurator site and click 'drums' to import the configuration. Now you can alter the configuration by changing the chosen country, add additional drums to the configuration etc.

SONOR continuously updates and expands the sq² drum system with new instruments, extra limited specials, veneers and finishes. Visit www.sq2-drumsystem.com regularly for an ever-changing new and updated experience in drum design.



TUNESAFE – right in tune, 100% of the time! All SONOR lugs are equipped with the patented Tunesafe, which prevents the tension rods from loosening. Tunesafe supports maximum tuning stability even under extreme environments.



SONOR
drums

20|21 SQ²

Walnut Brown Burst

SQ² Set in Walnut Brown Burst with Black Plated Hardware

Setup: Bass Drum 20" x 18" / Tom Toms 10" x 8", 12" x 9" / Floor Tom 14" x 14" / Snare Drum 13" x 6"

UPID 135575541207-1

SQ²
DRUM SYSTEM

The logo for SONOR drums, featuring a stylized drum icon to the left of the word "SONOR" in a bold, sans-serif font, with the word "drums" in a smaller font below it.

22 | 23 SQ²

SQ² - the most complete state-of-the-art custom drums available.
Build only by hand from master craftsmen, no drum is like another.

Start building your dream here:
WWW.SQ2-DRUMSYSTEM.COM

The logo for SQ² DRUM SYSTEM, with "SQ²" in a large, bold, sans-serif font and "DRUM SYSTEM" in a smaller, all-caps font below it.



Vintage Series



Vintage Set in Red Oyster **NEW**

Setup: Bass Drum 24" x 14" (WM) / Tom Tom 13" x 8" /
Floor Toms 16" x 14", 18" x 16" / Snare Drum 14" x 6.5"



the analog sound in a digital world

The new SONOR Vintage Series, Made in Germany

With the 140th Anniversary of the company, SONOR brings back an iconic sound and look of the time in between the 1950's and the early 1970's and proudly reveals the Vintage drum series, Made in Germany. Already in the 1960's SONOR Teardrop kits were build to highest quality standards, highly rated by international stars like Connie Kay, Sonny Payne or Kenny 'Klook' Clarke.



Rebirth

Bringing back the „old SONOR sound“ with rounded bearing edges. The result is a warm, dry but yet resonant sound. Shell Construction: 9 ply Beech shells with 6 mm shell thickness featuring SONOR's unique CLTF and OSM process.

Kenny 'Klook' Clarke

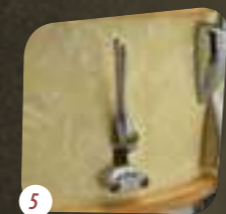
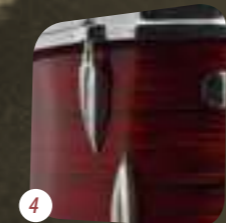
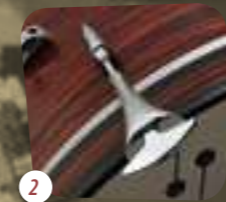
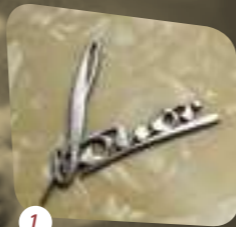

*pictures on this page show items and colors that are no longer available from SONOR

SONOR Teardrop kits are one of the most sought after vintage drums. Utilizing rounded bearing edges, the new Vintage series drums represent the return of the 'old SONOR sound' into its product line. SONOR introduced the 45 degree bearing edge in 1975, which we still use today on all SQ², Prolite, and Force series drums. With the addition of the Vintage Series, drummers will have access to a complete palette of sounds that is uniquely SONOR.

The SONOR team, in cooperation with artists and collectors, worked tirelessly to bring the new Vintage drum line as close as possible to the look, feel and sound of its predecessor the Teardrop drums. SONOR then combined its knowledge of modern drum building, with the look and sound of vintage drums, to create an instrument that will hold up to today's modern playing.

SONOR catalogue page of the 50's



Like in the original Teardrop drums, the Vintage drum series feature hand-selected premium German Beech shells with rounded bearing edges. We have carefully recreated the look and feel of the 1950's teardrop lug and updated it with SONOR's exclusive TuneSafe™ system. Being sure not to overlook any details, SONOR

has redesigned the Superprofil triple flanged hoops and brought back the timeless SONOR badge and logo used in between 1952 and 1961.

Vintage snare drums feature a new throw off. The 'Super 50', a completely redesigned strainer, was inspired by the throw off which was used on the SONOR D-411 and D-412 snares in the 1950's.



1) Original logo and new Vintage series logo 2) Original and new claw / tension rod design 3) Original Superprofil hoops from the 50's and redesigned new Superprofil version 4) Original and new Teardrop lugs 5) Original strainer design and redesigned Super 50 throw off (outside and inside mechanism)

Vintage Three 20 Shell Set in Vintage Onyx

Setup: Bass Drum 20" x 14" / Tom Tom 12" x 8" / Floor Tom 14" x 14"
additionally shown: Snare Drum 14" x 5.75"





New Bass Drum Bracket NEW

Vintage bass drums and shell sets are now available with the re-issue of the classic „iron“-shape bracket, which fits all SONOR single- and double-tomholder.

Vintage Reference

Vintage Bass Drums

Bass Drum	18" x 14"	VT 16 1814 BD NM
Bass Drum	20" x 14"	VT 16 2014 BD NM
Bass Drum	22" x 14"	VT 16 2214 BD NM
Bass Drum	24" x 14"	VT 16 2414 BD NM

NM = No Mount

Bass Drum	18" x 14"	VT 16 1814 BD WM
Bass Drum	20" x 14"	VT 16 2014 BD WM
Bass Drum	22" x 14"	VT 16 2214 BD WM
Bass Drum	24" x 14"	VT 16 2414 BD WM

WM = With Mount

Vintage Snare Drums

Snare Drum	14" x 5.75"	VT 15 14 x 5.75 SDW
Snare Drum	14" x 6.5"	VT 15 1465 SDW

Vintage Tom Toms

Tom Tom	10" x 8"	VT 15 1008 TT
Tom Tom	12" x 8"	VT 15 1208 TT
Tom Tom	13" x 8"	VT 15 1308 TT

Vintage Floor Toms

Floor Tom	14" x 12"	VT 15 1412 FT
Floor Tom	16" x 14"	VT 15 1614 FT
Floor Tom	18" x 16"	VT 15 1816 FT

Vintage Preconfigured Shell Sets

VT16 Vintage Three 20 Shell Set NM	BD 2014 NM, TT 1208, FT 1412
VT16 Vintage Three 22 Shell Set NM	BD 2214 NM, TT 1308, FT 1614

NM = No Mount

VT16 Vintage Three 20 Shell Set WM	BD 2014 WM, TT 1208, FT 1412, STH-VT 674 ML
VT16 Vintage Three 22 Shell Set WM	BD 2214 WM, TT 1308, FT 1614, STH-VT 674 ML

WM = With Mount



STH-VT 674 MC Single Tomholder
included with WM (With Mount) Shell Sets



Vintage Three 22 Shell Set in Vintage Pearl

Setup: Bass Drum 22" x 14" / Tom Tom 13" x 8" / Floor Tom 16" x 14"
additionally shown: Snare Drum 14" x 6.5"



Glem Kötche (Wilco)

Recommended

Wanna play just like back in the „Vintage“ days?
Try our 2000 Lightweight Series!

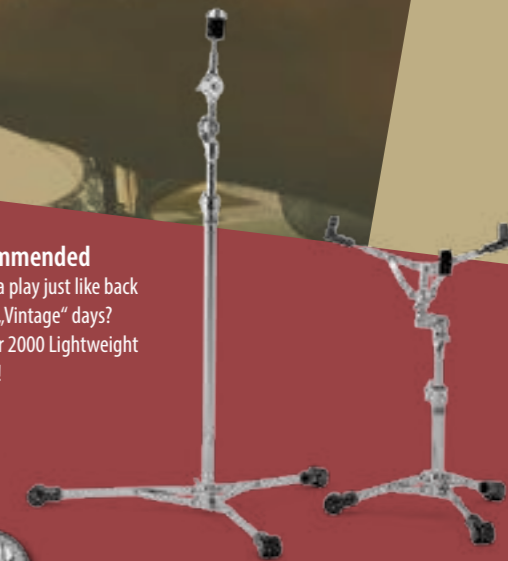

Tal Bergman (Joe Bonamassa)



TuneSafe - Right in Tune, 100% of the Time!
All SONOR lugs are equipped with the patented TuneSafe, which prevents the tension rods from loosening.



Vintage Onyx
Stain Satin Gloss

Vintage Natural
Stain Satin Gloss

Vintage Pearl
Wrap

NEW
Red Oyster
Wrap



Vintage Three 22 Shell Set in Vintage Natural
(additional items shown)



Vintage Three 20 Shell Set in Vintage Onyx
(additional items shown)

Vintage inside and outside
The stain satin gloss lacquered „Vintage Onyx“ and „Vintage Natural“, plus the stylish „Vintage Pearl“ and „Red Oyster“ wraps relate perfectly to the Teardrop era.

Did you know?
SONOR slotted tension rods are being offered as an option for those devoted to the SONOR „speciality“ and seeking to replace the square head tension rods on their Vintage series kits!
(item no. 190 343 01, 56 mm length, fits Tom Toms, Floor Toms and Snare Drums, pack of 6pcs.)



Did you know?
The „Superprofil“ hoop is an authentic remake of the hoop used on all Tom Toms, Floor Toms and Snare Drums built by SONOR until the 1970s.

Original image of 1955 SONOR catalogue

*ProLite
has got YOU
covered*

Chris Coleman

ProLite Set in Creme White

Setup: Bass Drum 22" x 17.5" / Tom Tom 10" x 8" / Tom Tom 12" x 9" /
Floor Tom 14" x 14" / Floor Tom 16" x 16" / Snare Drum 14" x 6" / Snare Drum 12" x 5"

SONOR ProLite Sound

The core of the ProLite series is the sound spectrum provided by the extremely thin Vintage Maple shells with reinforcement ring. These provide an unmistakably open sound and an enormously wide tuning range for practically all styles of music. SONOR's Vintage Maple shell is characterized by a soft, warm tone that highlights the lower pitches and provides balance in the mid-range and treble, without sacrificing projection and power.



ProLite Set in Ebony White Stripes

Setup: Bass Drum 22" x 17.5" (2x) / Tom Tom 10" x 8" /
Tom Tom 12" x 9" / Floor Tom 14" x 14" /
Floor Tom 16" x 16" / Snare Drum 14" x 6" /
Snare Drum 12" x 5"

Tomas Haake (Meshuggah)

SONOR ProLite Shell Design

SONOR cross-laminates shells for superior stability, sonically enhanced resonance and spectacular tone. The CLTF process is a result of years of research by SONOR craftsmen.

Optimum Shell Measurement (OSM)

SONOR implements a slightly narrow outside shell measurement for optimized head contact. This is a SONOR specialty, resulting in excellent tone, better sustain and controlled decay.

SONOR ProLite Shell Thicknesses

9 plies for tom toms, floor toms and snare drums = 4 mm + 2 mm Dynamic Edge reinforcement rings at the edge of the shells

12 plies for bass drums = 6 mm + 2 mm Dynamic Edge reinforcement rings at the edge of the shells



ProLite Reference

ProLite Bass Drums

Bass Drum	18" x 14"	PL 12 1814 BD WM
Bass Drum	20" x 17.5"	PL 12 2017 BD NM*
Bass Drum	22" x 15"	PL 14 2215 BD NM*
Bass Drum	22" x 17.5"	PL 12 2217 BD NM*
Bass Drum	24" x 14"	PL 14 2414 BD NM

NM* = No Mount / also available with Mount (WM)

ProLite Snare Drums

Maple Snare	12" x 5"	PL 12 1205 SDW
Maple Snare	13" x 5"	PL 12 1305 SDW
Maple Snare	14" x 5"	PL 12 1405 SDW
Maple Snare	14" x 5"	PL 12 1405 SDWD**
Maple Snare	14" x 6"	PL 12 1406 SDW
Maple Snare	14" x 6"	PL 12 1406 SDWD**
Steel Snare	14" x 5"	PL 12 1405 SDS
Steel Snare	14" x 5"	PL 12 1405 SDSD**
Brass Snare	14" x 5"	PL 12 1405 SDB
Brass Snare	14" x 5"	PL 12 1405 SDBD**
Brass Snare	14" x 6"	PL 12 1406 SDBD**

** = with die-cast hoops

ProLite Tom Toms

Tom Tom	8" x 7"	PL 12 0807 TT
Tom Tom	10" x 7"	PL 12 1007 TT
Tom Tom	10" x 8"	PL 12 1008 TT
Tom Tom	12" x 8"	PL 12 1208 TT
Tom Tom	12" x 9"	PL 12 1209 TT
Tom Tom	13" x 10"	PL 12 1310 TT
Tom Tom	14" x 11"	PL 12 1411 TT

ProLite Floor Toms

Floor Tom	14" x 12"	PL 12 1412 FT
Floor Tom	14" x 14"	PL 12 1414 FT
Floor Tom	16" x 14"	PL 12 1614 FT
Floor Tom	16" x 16"	PL 12 1616 FT
Floor Tom	18" x 16"	PL 12 1816 FT

ProLite Preconfigured Shell Sets

ProLite Studio 1 Shell Set	BD 2017 NM, TT 1008, TT 1209, FT 1414
ProLite Stage 3 Shell Set	BD 2217 NM, TT 1008, TT 1209, FT 1616

NM = No Mount / also available with Mount (WM)



Bass Drum Claws – Beautiful and Practical

The rubber insert beneath the bass drum claws assures that your wooden hoop will not be scratched. The recessed design of the tension rod and the raised synthetic insert of the bass drum claw protects your cases from snagging and scratching damage.



(T.A.R.) Total Acoustic Resonance Mounting System

Vibration free mounting results in pure tone and warm sustain. Enhanced by Total Acoustic Resonance and Advanced Projection System your Drum enjoys sonic freedom and stays mechanically stable, resulting in beautiful tone and unmatched projection.

ProLite Set in Chocolate Burl

Setup: Bass Drum 22" x 15" / Tom Tom 8" x 7" / Tom Tom 10" x 7" / Tom Tom 12" x 8" / Floor Tom 14" x 12" / Floor Tom 16" x 14" / Snare Drum 14" x 6"

Danny Carey (Tool) Picture by Bymne Stump

ProLite Set in Brilliant Black

Setup: Bass Drum 22" x 17.5" / Tom Tom 10" x 8" / Tom Tom 12" x 9" /
Floor Tom 14" x 14" / Snare Drum 14" x 6"

ProLite Set in Nussbaum

Setup: Bass Drum 18" x 14" / Tom Tom 12" x 8" / Floor Tom 14" x 14" / Snare Drum 13" x 5"





Ebony White Stripes
Veneer High Gloss



Brilliant Black
Solid High Gloss



Chocolate Burl
Veneer High Gloss



Nussbaum
Stain Satin Gloss



Creme White
Solid Matte



Natural
Stain Satin Gloss



ProLite Studio 1 Shell Set in Natural
Setup: Bass Drum 20" x 17.5" / Tom Tom 10" x 8" /
Tom Tom 12" x 9" / Floor Tom 14" x 14"
Additionally shown: Snare Drum 14" x 5"

Did you know?

SONOR was the 1st company to introduce 45 degree Bearing Edges in 1975. The result is a precise drumhead-to-shell-contact which allows for more tone.

Switzerland

Simon Baumann > Stephan Eicher
 Christoph Blattner > Rhythmtalk
 Fabian Bürgi > Müslüm, Tequila Boys
 Christoph Fluri > Chica Torpedos
 Tobias Heim > Kummerbuben, Tomazobi
 Pesche „DeeDee“ Kaufmann > Aeywaeg
 Pit Lee > Da Cruz
 Noby Lehmann > Rhythmtalk
 Ruedi Maurer > Rhythmtalk
 Jojo Mayer > Nerve
 Sandro Oberholzer > Independent
 Stefanie Ramseier > The Crumpets
 Ephraim Salzmann > Stefanie Heinzmann
 Philipp Schmid > Independent
 Dany Schnyder > Independent
 Muso Stamm > Independent
 Simon Steiner > Redeem
 Tom Steinmann > Treekillaz
 Domenic Schüpbach > Yokko
 Remo Signer > Independent
 Sascha Weber > Purpur, Setup
 Thomas Wild > van Dango, Schmetterband
 Guido Wyss > Enigmatik

New Zealand

Patrick Kuhlitz > Independent
 Darren Mathiassen > Shapeshifter / Hollie Smith
 Phil Rudd > AC/DC

Taiwan

Ming > Mayday

Malaysia

Martin Ngim > Independent

Australia

Joe Accaria > Jimmy Barnes/David Campbell
 Dom „Dcd“ Cabrera > Tim Omaji
 Dave Goodman > James Morrison
 Kevin Mendoza > Jessica Mauboy
 Evan Yako > Recording Artist

USA

Nasar Abadey > Independent
 Tal Bergman > Joe Bonamassa
 David Bowen > Cody Canada & the Departed
 Guillermo E. Brown > The Late Late Show
 Jaimeo Brown > Jaimeo Brown Trio
 Wild Mick Brown > Ted Nugent
 Rocky Bryant > Average White Band
 Dino Campanella > Dredg
 Danny Carey > Tool
 Chris Coleman > Prince
 Paul Collier > Angelcorpse
 Duduka Da Fonseca > Independent
 Jack DeJohnette > Independent
 Arti Dixon > Independent
 Dave Ferrara > Reach Around Rodeo Clowns
 Vinnie Fiorello > Less Than Jake
 Andres Forero > Hamilton Musical
 Ian Froman > Independent
 Derrick Frost > Chiodos
 Howie Gordon > Broadway
 Kris Gustofson > Independent
 Aaron Harris > Isis / Palms
 Tootie Heath > The Heath Brothers
 Mark Hernandez > Forbidden
 Orlando Hernandez > Chayanne
 Yoron Israel > Independent
 Fernando Jaramillo > Chayanne
 Jeffrey Jones > Independent
 Dean Kosh > Airborne
 Glenn Kotche > Wilco
 Rick Leith > One Slack Mind
 Shannon Leto > 30 Seconds to Mars
 Armand Majidi > Sick Of It All
 Samantha Maloney > Independent
 Sammy Merendino > Cyndi Lauper
 John Miceli > Meat Loaf
 Adam Nussbaum > The Impossible Gentlemen
 Kim Plainfield > Independent
 Nat Scott > Independent
 Leah Shapiro > Black Rebel Motorcycle Club
 Jared Shavelson > Boyssetsfire
 Jeff Sipe > Jimmy Herring
 Neal Smith > Independent
 Steve Smith > Vital Information
 Kenny Soule > Independent
 Mike Starcher > Independent
 Ed Udhuss > Zebrahead
 Jeff Tain Watts > Independent
 Kobe Watkins > Sonny Rollins
 Nathan Walker > Lit
 Ron Wikso > Greg Rolie
 Joe Winters > Steepwater Band
 Drummie Zeb > The Wailers

China

Guan Fei > Wang Feng Band
 Liu Gang > C.N.S.O
 Lu Xun > China Drummer Association
 Zheng Zhaohui Hao Zi > Independent

France

Mickael Boudoux > Independent
 Jacques Bourbasquet > Independent
 Frederic Degre > Independent
 Claude Gastaldin > Independent
 Christian Grassart > Independent
 Jo Hammer > Independent
 Marc Jacquemin > Cock Robin – FLOX
 Christian Monthieux > FFF - Independent
 Paco Sery > SIXUN
 Maxime Zampieri > Independent

Austria

Klaus Brennsteiner > Parametrix
 Werner Groisz > Les Humphrie Singers
 Christian Lettner > Basic Jazz Lounge
 David Piribauer > Independent
 Reinhard Schwarzingger > Independent
 Harald Tanschek > Independent

Benelux

Herman Cambré > Clouseau
 René Creemers > Drumbassadors
 Wim De Vries > Drumbassadors
 Hans Eijkenaar > The Voice Of Holland
 Juan van Emmerloot > Stef Burns
 John Engels > Independent
 Mark Eshuis > Independent
 Arend Nijs > Independent
 Gregory Pantophlet > Independent
 Ed Warby > Independent
 Sander Zoer > Delain

Canada

Tyler Stewart > Barenaked Ladies
 Chris Sutherland > Kinky Boots
 Johnny Fay > The Tragically Hip
 Sean Dalton > Independent
 Pat Stewart > Odds
 Jim Boudreau > The Western Swing Authority
 Aaron Edgar > Third Ion
 Rich Irwin > Florence K
 Chuck Keeping > Big Wreck
 Davide DiRenzo > Cassandra Wilson / Tom Cochrane
 Dave Langguth > Kim Mitchell
 Anthony Michelli > Independent
 Emmanuelle Caplette > Independent
 Jeff Asselin > The Lucas Haneman Express
 Roger Travassos > Michael Kaeshammer
 Aubrey Dayle > My id
 Steve Caron > Radio Radio
 Chris Lesso > Modus Factor
 Dave Patel > Emmanuel Jal
 Tim Timpleck > Emm Gryner / Trapper
 Andreas David > Ydna Murd
 Bryan Valeriani > Terminal Baggage Claim
 Alan Hetherington > Lenka Lichtenberg
 Brian Craig > Les Ékorchés
 Doan Pham > Independent
 Sean Kilbride > Independent
 Mario Roy > Independent
 Bruno Roy > Independent

Germany

Florian Alexandru-Zorn > Independent
 Christian Blüm > Brings
 Ronny Dehn > Silly
 Stephan Emig > Triosence
 Benny Greb > Moving Parts
 Carola Grey > Noisy Mama
 Holger Hälbig > Independent
 Rennie Hatzke > Münchener Freiheit
 Eike Herwig > Donots
 Sebastian Krajewski > Sseed / Peter Fox
 Raffael Kühle > OK Kid
 Thomas Lieven > Big Band der BW
 Rudi Marhold > Götz Alsmann
 Ralf Neuhaus > Independent
 Jost Nickel > Jan Delay
 Andreas Nowak > Silbermond
 Dennis Poschwatta > Guano Apes
 Pola Roy > Wir sind Helden
 Klaus Scharfschwerdt > Puhdys
 Christoph Schneider > Rammstein
 Joe Stypa > Konvoy / Cro / Cassandra Steen
 Ralph Winter > Big Band der BW
 Michael Wolpers > Victory

Norway

Rune Arnesen > Independent
 Jan Axel «Hellhammer» Blomberg > Mayhem
 Anders Engen > Bjørn Eidsvåg
 Bjørn Gunnar Sando > Hellbillies
 Claus Heiberg > Briskeby
 Sola Johnsen > Dum Dum Boys / Helter Skelter
 Espen Mangen > Independent
 Kim Ofstad > Dsound / Madcon
 Ole Petter Hansen Chylie > Dream Police / Ingrid Bjørnov/ Beat for Beat
 Agne Sæter > CC Cowboys

Italy

Enzo Augello > Educator
 Lele Boria > Educator
 Gianni Caltran > Session
 Francesco Corvino > Session
 Luciano Galloni > NEK
 Claudio Mastracci > Independent
 Fabio Nobile > Session
 Federico Paulovich > Destrage
 Franco Penatti > Session
 Sergio Pescara > Groovydo
 Daniele Pomo > RanetRane
 Giorgio Prette > Independent
 Franco Rossi > Educator
 Danilo Tasco > Negramaro

Argentina

Pablo LaPorta > Independent
 Gustavo Meli > Independent
 Jota Morelli > Independent
 Pedro Pacheco > Soledad Pastorutti
 Nicolas Polo > Asspera
 Andy Vilanova > Carajo

Japan

Yuki Aoyama > nano.RIPE
 Masao Fukunaga > Nana Mizuki
 Genta > Masayoshi Yamazaki, bird
 Naoya Hamada > Independent
 Yuki Hatano > YELLow
 Yuichi Hokazono > Spicy Kickin', Sphere
 Osamu Jinguji > Remioromen
 Taro Koyama > Independent
 Yuya Maeta > Martin Friedman
 Ken Ken Sato > Plastic Tree
 Yoshitaka Shirane > KREVA
 Akira Suefusa > Ego Wrappin' and the Gossip of Jaxx
 Masaaki Tamaki > Rimi Natsukawa, TUBE
 Yutaka Watanabe > Independent
 Hideo Yamaki > Independent
 Yuzo Yoshioka > Monster-Tairiku
 Yucky > Home Grown

Korea

Ji-Hyun Kim > Independent
 Junyong Quak > Independent

India

Ranjit Barot > John McLaughlin

United Kingdom

Steve Alexander > Independent
 Craig Bacon > Independent
 Richard Bailey > Incognito
 Ian Bayne > Runrig
 Dane Campbell > Straight Lines
 Jack Carrack > Paul Carrack
 Joe Crabtree > Wishbone Ash
 Danny Cummings > Mark Knopfler
 Blair Cunningham > Westernhagen
 James Chapman > Independent
 Guy Davis > Freeze the Atlantic
 Dave DeRose > Moloko/Roisin Murphy
 Martin Ditcham > Westernhagen / Status Quo
 Dean Duke > Paul Carrack
 Josh Gimber > Sons and Lovers
 Gavin Harrison > Porcupine Tree / King Crimson
 Ryan Jenkinson > Reverend & the Makers
 Martin "Magic" Johnson > Bewitched
 Jan Kincaid > Brand New Heavies
 Vinnie Lammi > Mel C / Spice Girls
 Joshua Blackmore > Squarepusher / Troyka
 Ed Lay > Editors
 Dafydd Leuan > Super Furry Animals
 John Marshall > Soft Machine Legacy
 Nicko McBrain > Iron Maiden
 Bryan McLellan > 24 Pesos
 Perry Melius > Tricky / Billy Ocean
 Brendan O'Neill > Nine Below Zero
 Alexis Nunez > The Kooks
 Chris "Jungle" Polglase > Independent
 Alex Reeves > Dizze Rascal
 Andy Robertson > Marlon Roudette
 Arnaldo Rogano > Future Shock
 Rocky Singh > Asian Dub Foundation
 Henry Spinetti > Katie Melua / Eric Clapton
 Richard Thair > Red Snapper
 Alex Toff > Jack McManus
 Paul Walsham > Hurts / Barclay James Harvest
 Colin Woolway > Independent

Sweden

Mikkey Dee > Motörhead
 Tomas Haake > Meshuggah

Indonesia

Yesaya "Echa" Soemantri – Independent
 Cendrianus (Cendi) Luntungan – CC&The Funky Stuff
 Yon Piliang – Independent

Did you know?

Our Ascent Series as well as Select and Essential Force Series feature our own T.A.R. (Total Acoustic Resonance) Tom Mounting System - Powerful sounds thanks to minimal shell contact!



Powerful performance Every time.

The SONOR Select Force series is the pinnacle of the Force range, featuring an all-maple shell. Designed with advanced and semi-professional drummers in mind, the Select Force Series can also be an interesting alternative for professional drummers. An array of pre-configured sets, components and the latest design in hardware and fittings make the SONOR Select Force series a recommended choice for the serious player!



Select Force Sounds

The 7 ply Canadian Maple shells offer uncompromisingly rich and warm sounds, highlight lower pitches and provide balance in the mid-range and treble. Whether in the woodshed, recording studio or on stage, SONOR's Select Force sets deliver a powerful performance every time.

- Shell Construction** 7 plies (5.8 mm) for Tom Toms, Floor Toms and Snare Drums
7 plies (7.2 mm) for Bass Drums
- Hoops** 2.3 mm Power Hoops on all Snare Drums
- Hardware Components** Tuning Lugs equipped with TuneSafe, prevents tension rods from loosening
Vibration-free T.A.R. Tom Mounting System
Rubber padded Bass Drum claws
Bass Drum spurs with memory locks
Bass Drum feet convertible from rubber to metal spike

- REMO® UT Drumheads** Tom Toms/Floor Toms: Emperor Style Clear, Snare Drums: Ambassador Style White Coated, Ambassador Style Resonant, Bass Drums: Powerstroke3 Style Clear, Powerstroke3 Style Black with SONOR Logo



Select Force Stage S Drive Set NM in Transparent Black Burst

Setup: Bass Drum 22" x 20" / Snare Drum 14" x 6.5" / Tom Tom 10" x 6.5" / Tom Tom 12" x 7" / Floor Tom 14" x 12" / Floor Tom 16" x 14"

Jared Shavelson (Boysatstfire)



Maple (11238)



Piano Black (11234)



Transparent Black Burst (13113)



Blue Galaxy Sparkle (13034)

Select Force Reference

Select Force Bass Drums

Bass Drum	20" x 17.5"	SEF 11 2017 BD WM
Bass Drum	22" x 17.5"	SEF 11 2217 BD WM
Bass Drum	22" x 20"	SEF 11 2220 BD NM

NM = No Mount / WM = with Mount

Select Force Snare Drums

Jungle Snare	10" x 2"	SEF 11 1002 SDJ
Maple Snare	13" x 7"	SEF 11 1307 SDW
Maple Snare	14" x 5.5"	SEF 11 1455 SDW
Maple Snare	14" x 6.5"	SEF 11 1465 SDW

Select Force Preconfigured Shell Sets

Select Force Studio Set	BD 2017 WM, SD 1455, TT 1008, TT 1209, FT 1414, 5-pc. HW 400 Set, DTH 4000
Select Force Stage 3 Set	BD 2217 WM, SD 1455, TT 1008, TT 1209, FT 1616, 5-pc. HW 400 Set, DTH 4000
Select Force S Drive Set	BD 2220 NM, SD 1465, TT 1065, TT 1207, FT 1412, FT 1614, 5-pc. HW 400 Set, 2 x MC 276, 2 x TA 4000

Select Force Jungle Set	BD 1616 WM, TT 1008, FT 1412, 5TH 4000
-------------------------	--

NM = No Mount / WM = with Mount

Color choices may differ from country to country

Select Force Tom Toms

Tom Tom	8" x 7"	SEF 11 0807 TT
Tom Tom	10" x 8"	SEF 11 1008 TT
Tom Tom	12" x 9"	SEF 11 1209 TT

Select Force Toms

Floor Tom	14" x 14"	SEF 11 1414 FT
Floor Tom	16" x 16"	SEF 11 1616 FT



4000-Series Hardware Set

— Reliable and Sturdy 'On the Road'!
The Hardware 4000 series provides road-ready double-braced stands with clever player-oriented solutions for maximum versatility, stability and reliability.

Select Force Studio Set in Maple

Setup: Bass Drum 20" x 17.5" / Snare Drum 14" x 5.5" / Tom Tom 10" x 8" / Tom Tom 12" x 9" / Floor Tom 14" x 14"

Essential Force Studio Set WM in Creme White

Setup: Bass Drum 20" x 17.5" / Snare Drum 14" x 5.5" / Tom Tom 10" x 8" /
Tom Tom 12" x 9" / Floor Tom 14" x 14"

Leah Shapiro (Black Rebel Motor Cycle Club)

*optimum
playing
comfort*



with professional features

The SONOR Essential Force series features a birch wood shell and is designed for advanced drummers not wanting to sacrifice their musical freedom. Five pre-configured sets and several components offer an array of possibilities for customizing configurations.



SONOR Essential Force Sounds

The 6 ply birchwood shells are a superb foundation for SONOR Essential Force sets. A hefty and dynamic sound – with accentuated mid-ranges and highs, and defined lows – are the hallmark of these shells. With high-gloss-lacquered natural wood surfaces, SONOR's Essential Force really steals the show.

Shell Construction

6 plies (7.2 mm) for Bass Drums, Tom Toms, Floor Toms and Snare Drums

Hardware Components

Tuning Lugs equipped with TuneSafe, prevents tension rods from loosening
Vibration-free T.A.R. Tom Mounting System
Rubber padded Bass Drum claws
Bass Drum spurs with memory locks
Bass Drum feet convertible from rubber to metal spike

REMO® UT Drumheads

Tom Toms/Floor Toms: Emperor Style Clear, Snare Drums:
Ambassador Style White Coated, Ambassador Style Resonant, Bass Drums:
Powerstroke3 Style Clear, Powerstroke3 Style Black with SONOR Logo

Essential Force Reference

Essential Force Bass Drums

Bass Drum	20" x 17.5"	ESF 11 2017 BD WM
Bass Drum	22" x 17.5"	ESF 11 2217 BD WM
Bass Drum	22" x 20"	ESF 11 2220 BD NM

NM = No Mount / WM = with Mount

Essential Force Snare Drums

Birch Snare	14" x 5.5"	ESF 11 1455 SDW
Steel Snare	14" x 5.5"	ESF 11 1455 SDS
Birch Snare	14" x 6.5"	ESF 11 1465 SDW

Essential Force Tom Toms

Tom Tom	8" x 7"	ESF 11 0807 TT
Tom Tom	10" x 8"	ESF 11 1008 TT
Tom Tom	12" x 9"	ESF 11 1209 TT
Tom Tom	13" x 10"	ESF 11 1310 TT

Essential Force Toms

Floor Tom	14" x 14"	ESF 11 1414 FT
Floor Tom	16" x 16"	ESF 11 1616 FT

Essential Force Preconfigured Shell Sets

Essential Force Studio Set	BD 2017 WM, SD 1455, TT 1008, TT 1209, FT 1414, 5-pc. HW 200 Set, DTH 4000
Essential Force Stage 3 Set	BD 2217 WM, SD 1455, TT 1008, TT 1209, FT 1616, 5-pc. HW 200 Set, DTH 4000
Essential Force S Drive Set	BD 2220 NM, SD 1465, TT 1065, TT 1207, FT 1412, FT 1614, 5-pc. HW 200 Set, 2 x MC 276, 2 x TA 4000

NM = No Mount / WM = with Mount

Essential Force Stage S Drive Set NM in Brown Fade

Setup: Bass Drum 22" x 20" / Snare Drum 14" x 6.5" / Tom Tom 10" x 6.5" / Tom Tom 12" x 7" / Floor Tom 14" x 12" / Floor Tom 16" x 14"



Piano Black (11234)



Creme White (13084)



Brown Fade (13073)



Amber Fade (11236)



Green Fade (13072)



Did you know?

Our Select and Essential Force Series Bass Drums are equipped with rubber padded bass drum claws to protect the wooden hoop against damage.

Color choices may differ from country to country



Did you know?

All SONOR lugs are equipped with the patented TuneSafe, which prevents the tension rods from loosening. TuneSafe supports maximum tuning stability even under extreme environments. Square-head tension rods with fine-pitch threads guarantee optimum tunability.

Smart Force Xtend Reference

Smart Force Xtend Bundle Sets	BD 1816 WM, SD 1455, TT 1008, TT 1209, FT 1414, 4-pc. Hardware Set, DTH 2000, MBS 53, DT 270, CB8 Cymbal Set (14HH, 16C, 20R)
Smart Force Xtend Combo Bundle Set	BD 2017 WM, SD 1455, TT 1008, TT 1209, FT 1414, 4-pc. Hardware Set, DTH 2000, MBS 53, DT 270, CB8 Cymbal Set (14HH, 16C, 20R)
Smart Force Xtend Studio Bundle Set	BD 2217 WM, SD 1455, TT 1008, TT 1209, FT 1414, 4-pc. Hardware Set, DTH 2000, MBS 53, DT 270, CB8 Cymbal Set (14HH, 16C, 20R)

WM = with Mount

Smart Force Xtend kits include additional Mini Boom Stand, Drum Throne and Cast Cymbal Set.



*off to
the right
start*

The SONOR Smart Force series has been designed with the beginner in mind, offering an attractive price point without compromising quality and sound. Offered in several stunning coverings and pre-configured sets, the SONOR Smart Force is the ideal choice for all up-and-coming rockers, jazz cats, enthusiasts of metal or blues ...or any drummer who's looking for a Drum set that is sturdy, yet versatile.

SONOR Smart Force Sounds

The 9 ply Poplar shells of the SONOR Smart Force sets are full bodied, providing balanced sound with lots of power up front. SONOR Smart Force Shell Design The Poplar shells deliver maximum strength, perfect roundness, and neutral Tuning thanks to the tension-free cross-lamination of the individual plies of wood (CLTF Cross Laminated Tension Free Process). The covered finish is very sturdy and long lasting, and the workmanship is impeccable.

Shell Construction 9 plies (7.2 mm) for Bass Drums, Tom Toms, Floor Toms and Snare Drums
Hardware Components Tuning Lugs equipped with TuneSafe, prevents tension rods from loosening Bass Drum feet convertible from rubber to metal spike. New Double Tom Holder with Ball Clamp

REMO® UX Drumheads Tom Toms/Floor Toms: Ambassador Style Clear, Snare Drums: Ambassador Style White Coated, Ambassador Style Resonant, Bass Drums: Powerstroke3 Style Clear, Powerstroke3 StyleBlack with SONOR Logo



Black (11229)



Brushed Blue (13004)



Wine Red (11228)

Smart Force Xtend Studio Set WM in Wine Red
Setup: Bass Drum 20" x 17.5" / Snare Drum 14" x 5.5" / Tom Tom 10" x 8" / Tom Tom 12" x 9" / Floor Tom 14" x 14"



Red Galaxy Sparkle

Turquoise Galaxy Sparkle

Silver Galaxy Sparkle

Gold Galaxy Sparkle

Black Galaxy Sparkle

SMALL CAR? SMALL STAGE? *don't* SMALL APARTMENT?
sacrifice your sound

Our Martini, Safari, Bop and Players kits offer compact size shells, but at the same time uncompromised sound. All drum kits feature a poplar shell combined with a covered sparkle finish and a tom holder. Cross-Laminated shells deliver superior stiffness, sonically pleasing resonance and spectacular tone. Tune Safe equipped lugs ensure that the tuning stays in place.



Did you know?

The approx. height of a full-grown Martini Special Edition kit is 80 cm (Standard setup, measured from floor to the top hoop of the tom tom), a full-grown Saint Bernard dog up to 90 cm in comparison.

Martini Special Edition in Gold Galaxy Sparkle

Setup: Bass Drum (with Mount & Riser) 14" x 12" / Tom Tom 8" x 8" / Floor Tom 13" x 10" / Steel Snare Drum 12" x 5"

Hardware: Single Tom Holder (STH 274)

Colors: Turquoise Galaxy Sparkle (13119) / Gold Galaxy Sparkle (17319) / Red Galaxy Sparkle (13116)



Safari Special Edition in Red Galaxy Sparkle

Setup: Bass Drum (with Mount & Riser) 16" x 16" / Tom Tom 10" x 8" / Floor Tom 14" x 12" / Snare Drum 14" x 5"

Hardware: Single Tom Holder (STH 274)

Colors: Red Galaxy Sparkle (13116) / Black Galaxy Sparkle (12795) /



Bop Special Edition in Silver Galaxy Sparkle

Setup: Bass Drum (with Mount) 18" x 16" / Tom Tom 12" x 8" / Floor Tom 14" x 14" / Snare Drum 14" x 5"

Hardware: Single Tom Holder (STH 274)

Colors: Silver Galaxy Sparkle (12796) / Red Galaxy Sparkle (13116)



Players Special Edition in Black Galaxy Sparkle

Setup: Bass Drum (with Mount) 20" x 12" / Tom Tom 10" x 8" / Floor Tom 14" x 12" / Snare Drum 14" x 5"

Hardware: Cymbal / Tom Combination Holder

Colors: Black Galaxy Sparkle (12795) / Gold Galaxy Sparkle (17319)

Florian Alexandru-Zorn



*the
heart*

of every beat

The snare drum is at the heart of every beat, centering the drum set with the most musical voice in your set-up. It's also the game changer in any musical setting – change the snare drum, and the band has a completely different sound. Get inspired by playing one of the finest instruments available to drummers today – SONOR snare drums!

when every beat counts

The exclusive SONOR Artist Snare series combines the experience of the world's most talented drummers with SONOR's vast percussion instrument manufacturing expertise. This partnership has produced unparalleled snare drum models which meet even the most stringent demands.

From brass to steel or bronze, from maple to beech and birch, each and every Artist Snare Drum is a masterpiece in its own right. During the development process, design is as integral to the final product as sound quality. This attention to detail gives each Artist Snare Drum its own unmistakable character. See for yourself on the following pages, or visit your SONOR instrument dealer to experience the tremendous quality of SONOR Artist Snares.



Adam Nussbaum

AS 16 1305 TI „Tineo“ **NEW**

The main feature of this Artist Snare Drum is the massive, 27 ply (and hence 28 mm thick) beechwood shell; this gives the snare a 'hefty' sound. It is deep, with lots of 'bottom', and yet transparent. Well suited for funk, fusion, jungle or electronic beats.

Features: 27 ply Beech shell, 26 mm shell thickness, 45° bearing edge, high gloss lacquer finish, 16 tension rods, TuneSafe, Dual Glide snare action, chrome plated fittings, 18 brass wires



AS 12 1405 MB „Scandinavian Birch“

With its thin Vintage Maple shell, this Artist Snare Drum offers excellent resonance and a clear, transparent sound. The classic Scandinavian Birch finish and the 24k gold-plated fittings give it a very high end look. Its warm and rich sound make this snare drum quite versatile and naturally suited to a wide variety of musical styles.

Features: 9 ply Vintage Maple shell, 4 mm shell thickness plus 2 mm Dynamic Edges, 45° bearing edge, satin lacquer finish, single flange hoops, 20 tension rods, TuneSafe, Dual Glide snare action, 24k gold-plated fittings, 18 bronze wires



AS 12 1405 BG Brass Gold

The best choice for drummers looking for an explosive, bright sound with a high level of force and soft shading. Offering a broad sound with sensitive response for all playing dynamics, this snare drum also features 24k gold-plated fittings.

Features: Brass shell, 1 mm shell thickness, 45° bearing edge, protection lacquer, die-cast hoops, 20 tension rods, TuneSafe, Dual Glide snare action, 24k gold-plated fittings, 24 brass wires



AS 12 1406 BRB Bronze Black

The "heavyweight" of the Artist series, this snare drum is made of a 14" x 6" cast bronze shell. Similar to the cymbal making process, the shell is made of one piece of bronze for best resonance and full projection. Offering maximum volume, it is the ideal Drum for music requiring a sharp, loud and powerful snare.

Features: Bronze shell, 3 mm shell thickness plus 2 mm Dynamic Edges, protection lacquer, die-cast hoops, 20 tension rods, TuneSafe, Dual Glide snare action, black-plated fittings, 24 bronze wires



AS 12 1205 AD „Art Design“

A 12 ply Birch shell with 12" x 5" size gives this snare drum a crisp, bright sound with plenty of attack. Whether using it as the main drum or as a side snare drum, the high pitched rim shots and sensitive response of the stainless steel wires ensure perfect sound performance. Ideal for the short breaks in drum 'n' bass, hip-hop or electronic pop.

Features: 12 ply Birch shell, 7 mm shell thickness, 45° bearing edge, high gloss lacquer finish, 16 tension rods, TuneSafe, Dual Glide snare action, chrome plated fittings, 18 stainless steel wires



AS 12 1406 CM „Cottonwood“

Perfect as an all-round snare drum this model features a 9 ply maple medium shell, a unique Cottonwood satin finish and die-cast chrome plated hoops. Producing a warm and full tone with a harmonic frequency, it also offers very clear attack and sensitive response due to the stainless steel wires.

Features: 27 ply Beech shell, 28 mm shell thickness, 45° bearing edge, high gloss lacquer „Tineo“ veneer, 16 tension rods, TuneSafe, Dual Glide snare action, chrome plated fittings, 18 brass wires



AS 12 1405 SB Steel Black

The heart of this Artist Snare Drum is a chrome-plated stainless steel shell. The perfect studio snare drum, it's also well suited to rock and funk drummers. Excellent rim shot sounds, a rich tone and a broad spectrum of medium-range and high pitches are other distinguishing features. The shell is equipped with black-plated hoops and fittings.

Features: Steel shell, 1 mm shell thickness, 45° bearing edge, protection lacquer, 20 tension rods, TuneSafe, Dual Glide snare action, black-plated fittings, 2 x 8 stainless steel wires



AS 12 1307 AM „Amboina“

The latest addition to the Artist Snare programme is the highly select 13" x 7" Amboina Snare. Constructed using a Heavy Maple shell, this snare drum embodies true perfection, only found in SONOR's superb quality construction. The sound ranges from sensitive moments to brute force – characterizing this all-around instrument with soft, warm tone in the lower pitches along with balanced mediums and highs. Using one of the finest burl wood veneers (Amboina) combined with 24k gold-plated fittings, this snare drum's look is breathtaking.

Features: 12 ply Heavy Maple shell, 8 mm shell thickness, 45° bearing edge, high gloss lacquer finish, 16 tension rods, TuneSafe, Dual Glide snare action, 24k gold-plated fittings, 18 brass wires

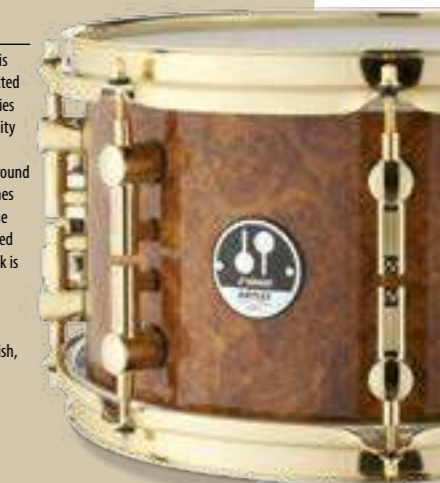



In late 2011, SONOR and Gavin began working on the "Protean" project with the goal to create a snare drum that is as musically versatile as Gavin himself. The name "Protean" comes from Greek mythology meaning "versatile" and "diverse". Gavin wanted this snare drum to be a daily workhorse instrument that can be quickly altered to suit the musical situation.

Construction and Finish

The Signature Snare is handcrafted in Germany and will be offered in two sizes, 14" x 5.25" and 12" x 5". They are made from 6-ply, 6 mm, hand-selected Birch featuring a timeless Silky Black finish which is offset by white underlays between the chrome fittings and the shell.

Hybrid Bearing Edges

The Snare reintroduces the vintage round bearing edge on top which SONOR last produced in 1975. On the bottom a modern 45 degree bearing edge is featured.

Hybrid Hoops

The Snares feature S-Hoops on the top side, and a special open, triple-flanged steel hoop on the bottom.

Vintage Lugs

Gavin's choice of lugs are the vintage Phonic lugs to add "mass" to the shell while eliminating stress from high tension.

Dual Glide System

Gavin loved the benefits of the new Dual Glide Snare System, but took the idea a little further. The open bottom hoop makes the Dual Glide strainer even more versatile, as multiple snare wires can be used and exchanged quickly. Tuning the bottom head with the snares off is much easier.

Unique Dampening Rings

Another special feature is a set of three newly designed dampening rings that are available in different widths (Light, Medium and Heavy dampening). Any range of overtone dampening can be achieved by using them separately or combined.

New Protean Tuning Keys

As a touring Pro, Gavin has to tune and exchange heads on a regular basis. Over the years he developed his own technique, which led to the development of a set of two special designed tuning keys. The Protean keys make the exchange of heads and tuning, easier, faster and more convenient.



Signature Snare Drums Gavin Harrison „Protean“ available models:

- SSD 13 1205 GH Standard Edition
- SSD 13 14x5,25 GH Standard Edition
- SSD 13 1205 GH Premium Edition
- SSD 13 14x5,25 GH Premium Edition



"Protean is the best of vintage meets modern innovation and to play it is my dream come true."
GAVIN HARRISON

Exclusive Snare Wires

Gavin designed three special 8 strand snare wire configurations. The standard assembled snare wire is the "Straight 8", which features 8 Stainless Steel strands in the center position. Available in the Premium Edition are: "EQ" - features 8 Bronze strands off center. "Spacer" - features 8 Brass strands in different diameter and unique spacing in between the strands.

Standard and Premium

The snares are available in a Standard and Premium Edition: The Standard Edition includes the snare, a set of 3 dampening rings and 2 Protean tuning keys. The Premium Edition additionally includes a unique Protean case, made by Hardcase UK. The case contains the "EQ" and "Spacer" snare wires, secured in a wooden box, separated from the drum itself.

Benny Greb

Since 2004, drumming scene's shooting star Benny Greb is part of the SONOR family. Says Benny: "For me as an artist it is key to embrace both tradition and innovation, and the guys at the Sonor Drum company do that same thing. I feel close to people that love what they do and who are dedicated to quality. That's why I feel close to the Sonor Company." Benny can be found playing with an assortment of musicians, all demanding his tasteful and immaculate playing style. Early 2010, SONOR and Benny begun working on a very special Snare Drum, Benny's very own Signature model that is as versatile and musical as Benny himself. Benny favors Beech, and that's what gives the Drum its transparency, warmth and a wide tuning range with a fat sound. The beautiful outer veneer is Scandinavian Birch that adds a timeless look to the Drum. But it wouldn't be Benny without adding something very special. The personalized Benny Greb badge shows his unique "Cartoon-head", and a synthetic design ring is being applied to the shell.



"In all of my recent recordings you can hear the huge sound and versatility of this great instrument. I'm happy to share this sound now with you. Have fun with it!"
Benny Greb

Signature Snare Drum Benny Greb (SSD 10 13x5.75 BG)

13" x 5.75" Signature Snare Drum, Scandinavian Birch, satin lacquered finish, equipped with a specially designed Benny Greb badge and synthetic design ring, 9 ply Thin Beech shell, 5 mm shell thickness, 45° bearing edge, Artist series lugs with TuneSafe, 16 tension rods, 2.3 mm Power Hoops, throw-off snare action, chrome-plated shell



Mikkey Dee

Mikkey, best known as the Drum-Powerhouse for Rock'n Roll's loudest live-band: Motörhead, has been part of the SONOR family of artists for more than 30 years. After filling the drum throne for artists such as King Diamond & Dokken and having appeared on numerous recordings, Mikkey joined Motörhead in the early 90's. His style, both unique and powerful is recognized as the key ingredient to Motörhead's thunderous sound! The 14" x 7.25" Snare Drum features Mikkey's favorite shell construction, a 6 ply Birch shell. A shell that is known for its wide tuning range, powerful mids and highs, and well balanced low end. A thrilling artwork by Motörhead's album designer Mark Devito features some of Rock's most popular icons and perfects the latest addition to SONOR's growing Signature Snare Drum line.



"This is the actual size I've been playing all these years with SONOR. It delivers a well balanced tone and is loud enough to catch up with Motörhead. Check it out, you will love it."
Mikkey Dee

Signature Snare Drum Mikkey Dee (SSD 12 14x7.25 MD)

14" x 7.25" Signature Snare Drum, 6 ply Birch shell, 7.2 mm shell thickness, 45° bearing edge, chrome shell hardware, unique Motörhead wrap design by Mark Devito, SONOR design tuning lugs with TuneSafe, 20 tension rods, throw-off snare action, 2.3 mm Power Hoops, Signature series badge, equipped with REMO drumheads, 20 steel wires

Phil Rudd

With over 30 years of deep relationship, SONOR and Phil Rudd teamed up to create a unique and exclusive Signature Snare Drum model. The Snare Drum is based on Phil's all-time favourite Snare Drum, the SONOR Horst Link Signature Brass model, while adding exciting new features and face. The final prototype Snare Drum was presented to Phil in early 2009 during the "Black Ice" World Tour and used from thereon.



"I'm always looking for a fat intimidating sound that's punchy with an edge on it"
Phil Rudd > AC/DC

Signature Snare Drum Phil Rudd (SSD 11 1405 PR)

14" x 5" Signature Snare Drum, Chrome over Brass, equipped with a signed Re-Issue of the 1980's Signature badge, Brass shell, 1.2 mm shell thickness, 45° bearing edge, Artist series die-cast hoops, 20 tension rods, TuneSafe, throw-off snare action, chrome-plated shell hardware, 20 steel wires



Steve Smith

Steve Smith, one of the world's greatest drummers, has been endorsing SONOR Drums for more than 30 years. Steve and the SONOR engineers created a true masterpiece that is addicted to sound, features, design and most of all, Steve's input. The 14" x 5.5" Signature Snare Drum is an outstanding instrument, made out of an exclusive, 2.5 mm cast steel shell / 2.5 mm reinforcement rings and two air vents.

Vintage style Phonic lugs with integrated TuneSafe are in place for a vintage look, and die-cast hoops and a REMO fiberskyn 3 batter head in Diplomat thickness add to the overall effect of what Steve is looking for in a snare drum: a crisp, full-bodied instrument with an immediate and effortless playing response.

Besides the Signature badge, Steve's Signature is engraved on a Re-Issue of the "Hilite Exclusive" badge, adding another "Vintage SONOR" touch.



"SONOR drums have remained my first and only choice as a high quality instrument for the past 30 years. My sound is the 'SONOR sound', I can't imagine playing any other drum kit"
Steve Smith

Signature Snare Drum Steve Smith (SSD 11 1455 STS)

14" x 5.5" Signature Snare Drum, Chrome, equipped with a signed Re-Issue of the 1988's Hilite Exclusive badge, cast steel shell, 2.5 mm shell thickness with 2.5 mm reinforcement rings, 45° bearing edge, Phonic series Re-Issue tuning lugs with TuneSafe, 20 tension slotted rods, REMO Fiberskyn 3 Diplomat batter head, Artist series die-cast hoops, 2 hidden ventholes, throw-off snare action, chrome-plated shell hardware, SONOR SoundWire with 24 stainless steel wires

PHONIC SNARE DRUMS

the
re-issuE
OF THE FAMOUS PHONIC SNARE DRUM

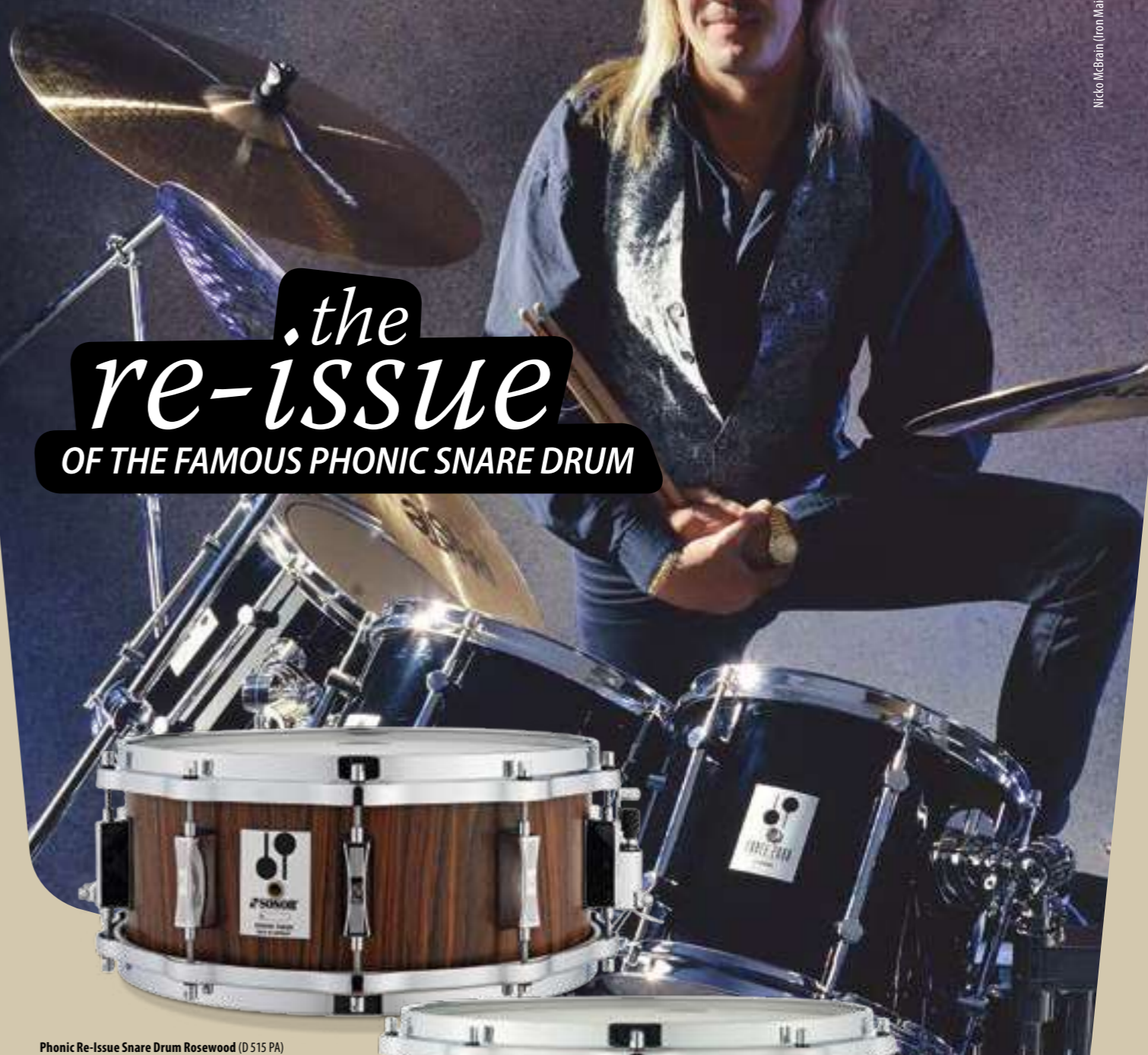

Nicko McBrain (Iron Maiden)

Phonic Re-Issue Snare Drum Rosewood (D 515 PA)

14" x 5.75" Re-Issue Snare Drum, 12 ply Beech shell, 10.5 mm shell thickness, 45° bearing edge, Rosewood outer and inner veneer, chrome shell hardware, Phonic double lugs, 20 slotted tension rods, die-cast hoops, throw-off snare action, vintage Phonic series badge, REMO USA drumheads

Phonic Re-Issue Snare Drum Mahogany (D 516 MR)

14" x 6.5" Re-Issue Snare Drum, 9 ply Beech shell, 8.5 mm shell thickness, 45° bearing edge, Mahogany outer and Beech inner veneer, chrome shell hardware, Phonic double lugs, 20 slotted tension rods, die-cast hoops, throw-off snare action, vintage Phonic series badge, REMO USA drumheads Throw-Off Snare Action Phonic snare drums feature the SONOR throw-off snare action.



DUAL GLIDE SYSTEM

The Dual Glide Snare strainer mechanism features a technically perfected snare wire engage and release system, along with great adjustability and a solid look and feel. SONOR Dual Glide System refers to the precise and smooth action, which in turn eliminates any unwanted sounds when the snare wires are placed in ON or OFF position. Both the strainer and butt sides are equipped with a quick-release snare wire detach function, allowing the drummer to change the resonant head without having to loosen and adjust the snare wires. A fine-tune adjustment knob is employed on both sides.

Thanks to the well thought-out design and construction, the new Dual Glide strainer also works to replace the current strainer on most of SONOR's snare drums, and is available as an individual component.

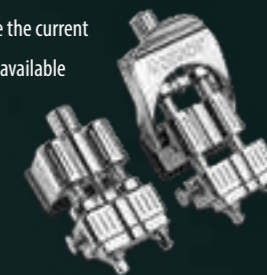

ProLite Snare Drums Reference

ProLite Snare Drums		
Maple Snare	12" x 5"	PL 12 1205 SDW
Maple Snare	13" x 5"	PL 12 1305 SDW
Maple Snare	14" x 5"	PL 12 1405 SDW
Maple Snare	14" x 5"	PL 12 1405 SDWD*
Maple Snare	14" x 6"	PL 12 1406 SDW
Maple Snare	14" x 6"	PL 12 1406 SDWD*
Steel Snare	14" x 5"	PL 12 1405 SDS
Steel Snare	14" x 5"	PL 12 1405 SDSD*
Brass Snare	14" x 5"	PL 12 1405 SDB
Brass Snare	14" x 5"	PL 12 1405 SDBD*
Brass Snare	14" x 6"	PL 12 1406 SDBD*

* = with die-cast hoops



12" x 5" Maple Snare in Creme White (PL 12 1205 SDW)
16 tension rods, TuneSafe, 2.3 mm Power Hoops, 9 ply Vintage Maple shell, 4 mm thickness plus 2 mm reinforcement rings, 45° bearing edge



13" x 5" Maple Snare in Nussbaum (PL 12 1305 SDW)
16 tension rods, TuneSafe, 2.3 mm Power Hoops, 9 ply Vintage Maple shell, 4 mm thickness plus 2 mm reinforcement rings, 45° bearing edge



14" x 5" Maple Snare in Brilliant Black (PL 12 1405 SDW)
20 tension rods, TuneSafe, 2.3 mm Power Hoops, 9 ply Vintage Maple shell, 4 mm thickness plus 2 mm reinforcement rings, 45° bearing edge



14" x 5" Maple Snare in Natural (PL 12 1405 SDWD)
20 tension rods, TuneSafe, die-cast hoops, 9 ply Vintage Maple shell, 4 mm thickness plus 2 mm reinforcement rings, 45° bearing edge



14" x 6" Maple Snare in Ebony Stripes (PL 12 1406 SDW)
20 tension rods, TuneSafe, 2.3 mm Power Hoops, 9 ply Vintage Maple shell, 4 mm thickness plus 2 mm reinforcement rings, 45° bearing edge



14" x 6" Maple Snare in Chocolate Burl (PL 12 1406 SDWD)
20 tension rods, TuneSafe, die-cast hoops, 9 ply Vintage Maple shell, 4 mm thickness plus 2 mm reinforcement rings, 45° bearing edge



14" x 5" Steel Snare (PL 12 1405 SDS)
20 tension rods, TuneSafe, 2.3 mm Power Hoops, 1 mm shell thickness, 45° bearing edge



14" x 5" Steel Snare (PL 12 1405 SDSD)
20 tension rods, TuneSafe, die-cast hoops, 1 mm shell thickness, 45° bearing edge



14" x 5" Brass Snare (PL 12 1405 SDB)
20 tension rods, TuneSafe, 2.3 mm Power Hoops, 1 mm shell thickness, 45° bearing edge



14" x 5" Brass Snare (PL 12 1405 SDBD)
20 tension rods, TuneSafe, die-cast hoops, 1 mm shell thickness, 45° bearing edge



14" x 6" Brass Snare (PL 12 1406 SDBD)
20 tension rods, TuneSafe, die-cast hoops, 1 mm shell thickness, 45° bearing edge



1900



1920 Charleston



1920 Perfecta



1920 Sonor



1927 Duplex



1930 Hollywood



1931 Cyklop



1940 Sonor



1950 Sonor



1957 Presto Z 5308



1956 Sonor



1954 Rasant



1950 Standard



1950 Sonor



1945 Sonor



1960 Sonor



1960 Sonor



1964 Tempo



1964 Presto Z 5318



1968 Sonor



1975 Z 5303

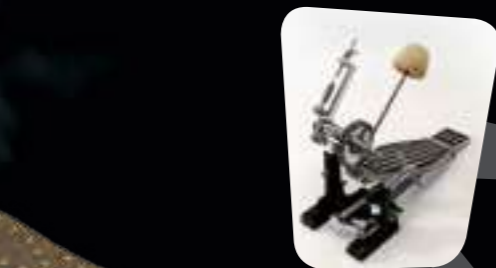

1984 Signature HLZ 5380



1980 Phonic Z 5325
"Daniel Humair"



1980 Phonic Z 5321
Excentric-Action



1980 Phonic Z 5317
Heavy-Duty



1975 Z 5318



1990 Performer Z 5365



1993 Force 2000 FZ 2093



1998 Force 2001



2001 Giant Step
Twin Effects



1927 The „Duplex“



2012 The „Perfect Balance“



PERFECT BALANCE BY JOJO MAYER

The main philosophy behind this pedal is to achieve perfect harmony and interplay between the pedal's moving parts and your foot. Due to careful design and perfectly balanced linear action any non-vital adjustments are obsolete and omitted on purpose. Other than the pedal's folding and mounting mechanism, all adjustments such as spring tension, footboard height and beater angle are classic, industry standard solutions.

„The Perfect Balance Pedal is a carefully calibrated system that optimizes the linear translation of your foot movements and makes many adjustments expendable. It was designed with a principle in mind that reflects ultimate sophistication to me:

Simplicity.

Essentially, it could be described as the soul and feel of a vintage pedal reincarnated in the technology of a 21st century body.“

Jojo Mayer

Jojo Mayer



Self mounting clamp



Push button for folding



Spring hold by a magnet

Low Mass Drive System

The drive cam and beater hub are streamlined into a single unit for low mass and carefully calibrated for perfectly balanced strokes. Round cam design creates linear acceleration which is a major advantage for many hybrid techniques.

Elongated Board

Elongated and smooth footboard adds more leverage to the stroke and allows extended range of movement for heel toe and sliding techniques.

Self Mounting Clamp

Quick mounts the pedal with a single motion. Clamp adjusts to all hoop thicknesses.

Ballistic Fiber Strap

Ballistic fiber strap minimizes inertia of the drive system and offers a quicker and smoother response than chain or solid drives.

Folding Mechanism

Folds the pedal into compact size for easy transportation with the push of a button. For extended lifespan, the spring can be dislocated and secured with a magnet when folded.



Perfect Balance Pedal

Bass Drum Single Pedal, with ballistic fiber strap, self mounting clamp, push button for folding, spring hold by a magnet, pedal bag

GIANT STEP

Maximum Speed and Power

SONOR Giant Step bass drum pedals are the best tool for discriminating drummers refusing to sacrifice any musical freedom. As a state-of-the-art pedal, Giant Step delivers an optimum feel for the music along with speed and handling. The extraordinary design and numerous enhancement options elevate Giant Step pedals to a class unto themselves. From the Target Point foot board to the docking station, every aspect of the Giant Step series has been designed with the utmost attention to detail.



GSP 3 Single Pedal

Target Point, Rotation Pendulum, Smart Connect and Docking Station¹.

Docking Station¹ Smart Connect System

– The Flexible Pedal Attachment

The "Smart Connect" system means quick and effortless attachment of the pedal with an adjustable ball clamp through a firm lever mechanism. A cylindrical axle connection neutralizes any possible tensions traditionally caused by different bass drum angle positions.

Anti Slip Rubber – Get a grip on any surface!

The bass drum plate has an anti-slip rubber profile with self-adhesive velcro.



Docking Station



SCH 28

SCH 20



GSC

GSH

GSR

GDPR 3 Double Pedal

This double pedal effectively demonstrates the modular system of the Giant Step series. Separate modules of the Single pedal make up the double pedal, featuring extremely smooth action. The connecting axle is length adjustable, and the high quality cross joints are covered by rubber housings.



¹) US pat. 6.632.990
EU pat. 1.237.146

Did you know?

The first SONOR pedal dates back to the year 1900! It is on display in the SONOR museum at the company's headquarter in Germany.



600 Series PEDALS

600 series

- Bass drum pedal utilizing Giant Step design
- Smooth, fast pedal action due to unique SONOR construction
- Smart Connect System with Docking Station for quick and reliable bass drum mounting
- Two way beater for choice of attack sound
- Adjustable toe stop



SP 673

Bass Drum Single Pedal, with bag, Smart Connect System, Docking Station, two way beater, adjustable toe stop

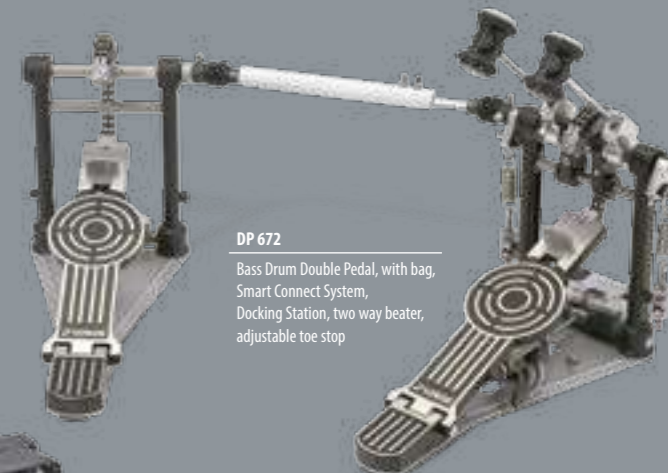

DP 672

Bass Drum Double Pedal, with bag, Smart Connect System, Docking Station, two way beater, adjustable toe stop



Pedal Bag



Docking Station



SP 473

Bass Drum Single Pedal, with support board and adjustable toe stop



Pedal Bag

400 Series PEDALS

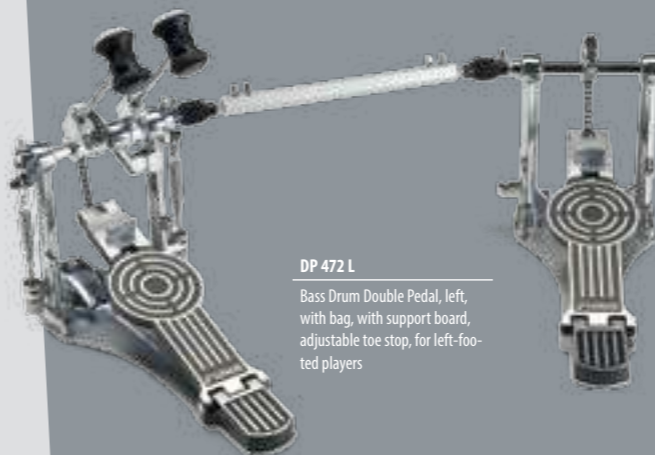

DP 472 L

Bass Drum Double Pedal, left, with bag, with support board, adjustable toe stop, for left-footed players



DP 472 R

Bass Drum Double Pedal, right, with bag, with support board, adjustable toe stop

600 / 6000 Hardware Series

The pinnacle of SONOR hardware. Offering maximum reliability and optimum handling with lots of individual components. Professional down to the smallest detail! The 3-section clamp diffuses the force around three sides of a stand rod like no other clamp does! Plus, it can be secured easily. The independently adjustable base leg of the hardware 600 suits each drummer's individual set-up. Completely retractable cymbal boom arm converts the mini boom stand to a straight cymbal stand.

400 / 4000 Hardware Series

Professional, road-ready hardware at an unbeatable price. Equipped with lots of individual components, the 400 / 4000 Series is easy to set up, adjust and tear down. Completely retractable cymbal boom arm converts the mini boom stand to a straight cymbal stand.

2000 Hardware Series

SONOR's basic hardware series is characterized by good handling with professional appearance. The hardware standard with lots of grip for added playing confidence.



Hi-Hat Stands

600 Hardware Hi-Hat Stands

HH 674 MC Hi-Hat Stand (see HH 684)
HH 684 MC Two-Leg Hi-Hat Stand, with adjustable spring tension, swivel foot board, retractable, with toe stop, 7-step bottom cymbal tilter, legs convertible from rubber to metal spurs, hexagonal pull rod and clutch prevents top hi hat cymbal from loosening.

400 Hardware Hi-Hat Stand

HH 400 Hi-Hat Stand with adjustable spring tension, swivel foot board, retractable, with toe stop, 7-step bottom cymbal tilter

200 Hardware Hi-Hat Stands

HH 200 Hi-Hat Stand with swivel footboard
HH XS 200 Hi-Hat Stand, extra low, adjustable height range: 650 mm - 820 mm



Bottom Cymbal Tilter Secure-Fastening Massive and Flexible

7-step, easy to operate cymbal tilter (Hi Hat Models HH 674 MC, HH 684 MC and HH 400 only)



Drum Thrones

6000 Hardware Drum Thrones

DT 6000 RT Drummer's Throne, round seat, with spindle, with Drum Key Holder, adjustable height range: 460 mm - 660 mm
DT 6000 ST Drummer's Throne, saddle seat, with spindle, with Drum Key Holder, adjustable height range: 460 mm - 660 mm

4000 Hardware Drum Thrones

DT 4000 Drummer's Throne, round seat, with spindle, with Drum Key Holder, adjustable height range: 460 mm - 620 mm

2000 Hardware Drum Thrones

DT 2000 Drummer's Throne, round seat, extractable tube, with Drum Key Holder, adjustable height range: 440 mm - 600 mm
DT XS 2000 Drummer's Throne, extra low, adjustable height range: 390 mm - 560 mm



Drum Key Holder

The search for a drum key is history: with the innovative SONOR drum key holder you can always find your key right under the throne top.

DT 6000 RT Round Top / DT 6000 ST Saddle Top

- New 2-segment top / tube clamp
- New tuning key holder included
- Spindle drive
- Reinforced brace connection
- New round and saddle throne tops with improved comfort padding and shape
- New rubber foot design



Derrick Frost (Chiodos)

Cymbal Stands

74 | 75 **HARDWARE**

600 Hardware Cymbal Stands

- CBS 672 MC** Cymbal Boom Stand, 400 mm boom arm length, 360° rotation
- MBS 673 MC** Mini Boom Stand with retractable boom arm, 485 mm boom arm length

4000 Hardware Cymbal Stands

- MBS 4000** Mini Boom Stand with retractable boom arm, 285 mm boom arm length

2000 Hardware Cymbal Stands

- MBS 2000 V2** Mini Boom Stand, 285 mm boom arm length
- MBS LT 2000 V2** Mini Boom Stand, single braced
- MBS 53** Mini Boom Stand, 285 mm boom arm length

All 4000 and 2000 series hardware Cymbal tilter feature a rubber cymbal sleeve cup. This sleeve cup gives your Cymbal a secure hold and protects the cymbal from the tilter thread.

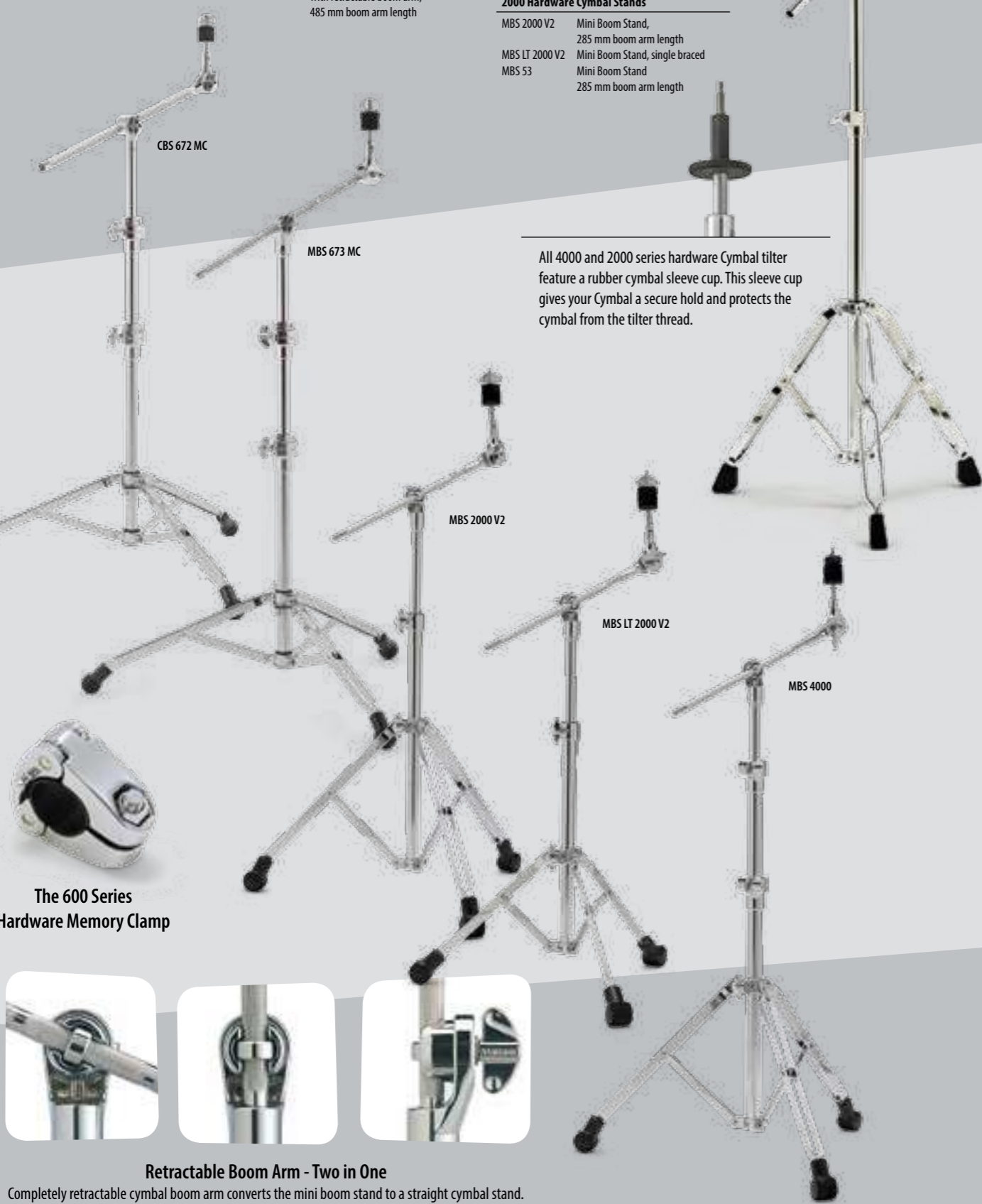

Double Cymbal Stands

600 Hardware Cymbal Stands

- DCS 678 MC** Double Cymbal Stand with two cymbal boom arms

4000 Hardware Cymbal Stands

- DCS 4000** Double Cymbal Stand with two cymbal boom arms

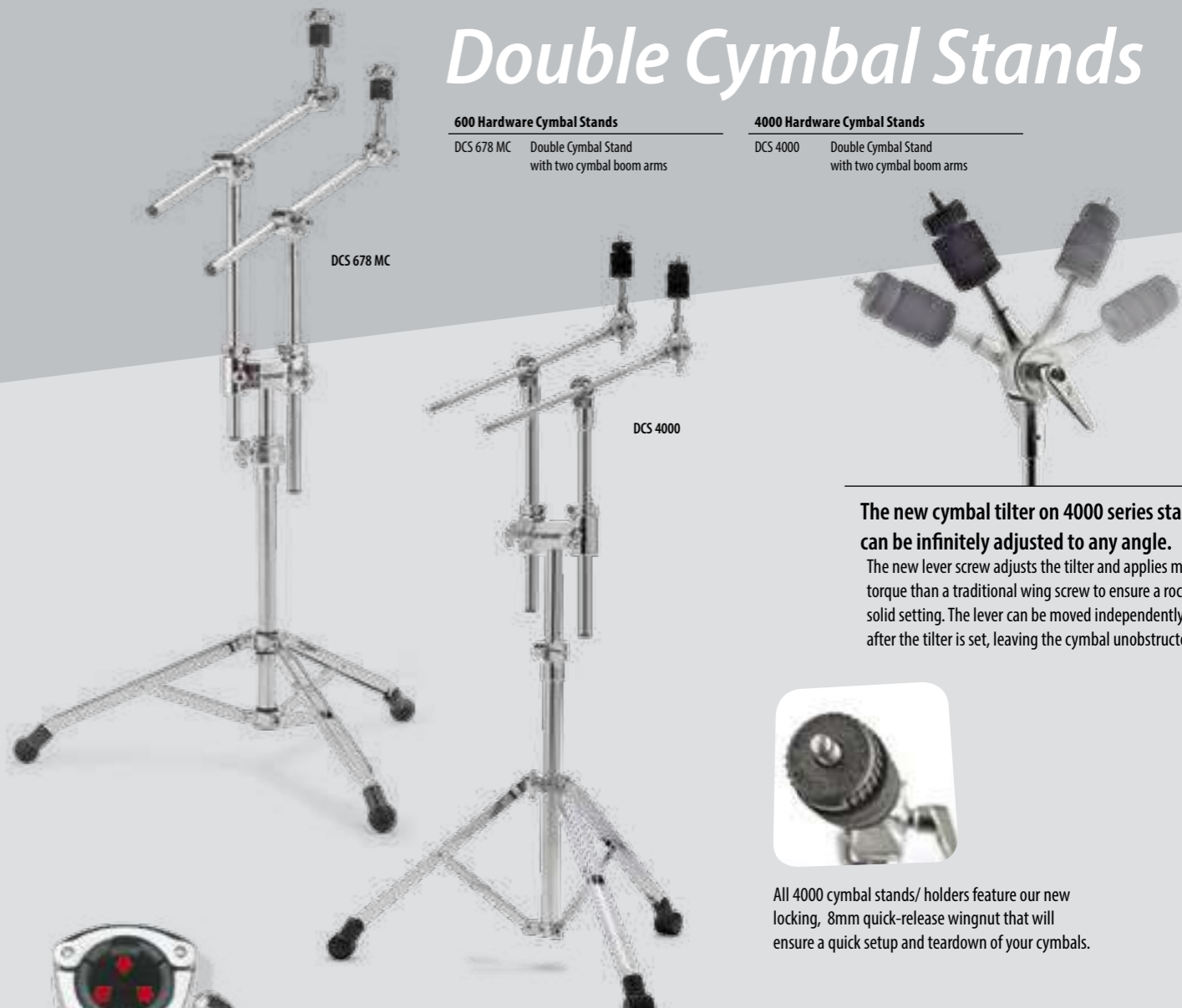

The new cymbal tilter on 4000 series stands can be infinitely adjusted to any angle.

The new lever screw adjusts the tilter and applies more torque than a traditional wing screw to ensure a rock solid setting. The lever can be moved independently after the tilter is set, leaving the cymbal unobstructed.



All 4000 cymbal stands/ holders feature our new locking, 8mm quick-release wingnut that will ensure a quick setup and teardown of your cymbals.

The 600 Series Hardware Memory Clamp



Retractable Boom Arm - Two in One

Completely retractable cymbal boom arm converts the mini boom stand to a straight cymbal stand.

3-Section Clamp¹

The 3-section clamp diffuses the force around three sides of a stand rod like no other clamp does! Plus, it can be secured easily.



New 4000 Series 2-Segment Memory Clamp



Cymbal Boom Arms

600 Hardware Cymbal Arm

- CBA 671 MC** Cymbal Boom Arm, 400 mm boom arm length, 360° rotation

600 Hardware Mini Boom Arm

- MBA 4000** Mini Boom Arm, 285 mm boom arm length



Did you know?

The legs of all our hardware 600 and 6000 stands are equipped with solid stainless steel rivets. Built to last: we take it serious. That's why we offer a Lifetime Warranty on the riveting of our 600 and 6000 Series stands.



¹) DE pat. 1023 57 515

Snare Stands

600 Hardware Snare Stands

SS 677 MC Snare Drum Stand with quick release lever, adjustable height range: 490 mm - 730 mm

4000 Hardware Snare Stands

SS 4000 Snare Drum Stand with toothless snare basket adjustment, adjustable height range: 490 mm - 660 mm

2000 Hardware Snare Stands

SS 2000 Snare Drum Stand, adjustable height range: 470 mm - 640 mm
 SS XS 2000 Snare Drum Stand, extra low, adjustable height range: 380 mm - 540 mm
 SS LT 2000 Snare Drum Stand, single braced, adjustable height range: 470 mm - 640 mm



Quick Release Lever - Couldn't Be Easier!

No more complicated screws ever again! Simply lay the snare drum on the stand and flip the lever - that's it.



SS 677 MC

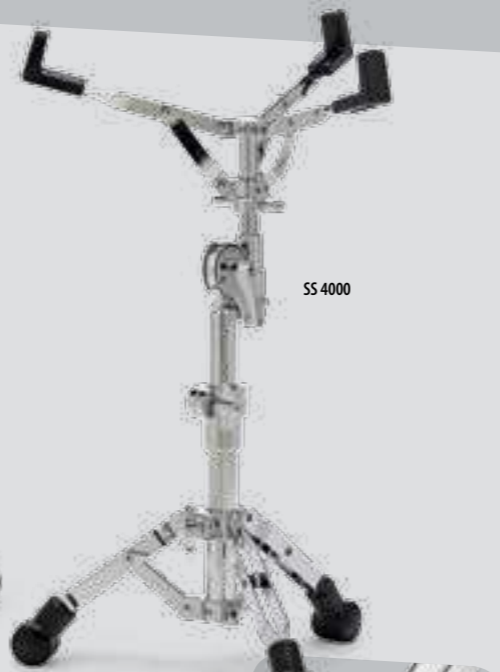

SS 4000



The new rubber foot design enhances stability and ground contact of the stands.

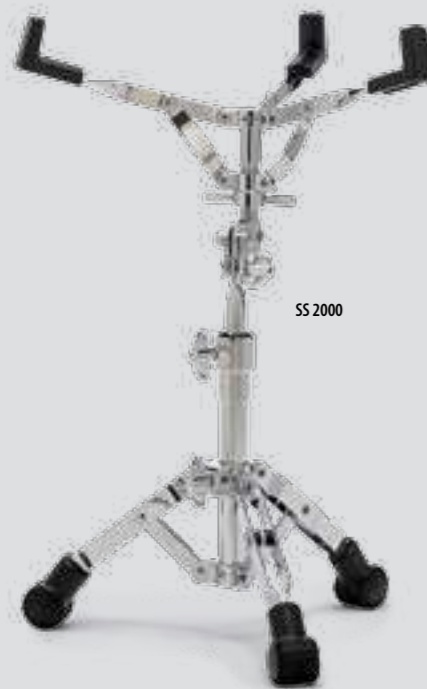

SS 2000



SS LT 2000



SS XS 2000

Combination Stands

600 Hardware Combination Stand

CTS 679 MC Cymbal Tom Stand with tom arm with ball clamp² and cymbal boom arm

4000 Hardware Combination Stand

CTS 4000 Cymbal Tom Stand with tom arm with ball clamp² and cymbal boom arm

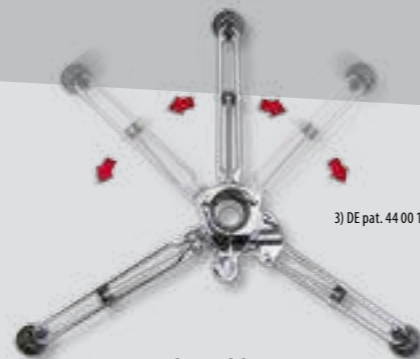

3) DE pat. 44 00 151 / JP pat. 2 564 110 / US pat. 5 509.629

Adjustable Leg - Fits Every Configuration³
 The independently adjustable base leg of the hardware 600 suits each drummer's individual set-up.



CTS 4000

CTS 679 MC

2) DE pat. 43 33 913 / GB pat. 2 273 043 / US pat. 5.803.642

Tom Stands

600 Hardware Tom Stands

DTS 675 MC Double Tom Stand, 2 tom arms with ball clamp²
 STS 676 MC Single Tom Stand with tom arm with ball clamp²

4000 Hardware Tom Stands

DTS 4000 Double Tom Stand, 2 tom arms with ball clamp²
 STS 4000 Single Tom Stand with tom arm with ball clamp²



DTS 675 MC

STS 676 MC

DTS 4000

STS 4000

the Basic Arm System

Freedom, Flexibility & Function

The Basic Arm System allows you to create your own customized individual hardware setup. The Basic Arm System is divided into the Basic Arm 19 and Basic Arm 12, reflecting the variation in tube diameters. We utilize identical ratchets overall for ease of compatibility between the components. The details are too many to mention – experiment and design the Basic Arm System of your own.



BA19-BSS MC, BR12 MC, 3x BA-CH, BA-PA, MH-PC



Simply combine and assemble your Basic Arm components.



Easy and clever: Depending on the combination of your Basic Arm components simply remove a glide ring.



Basic System

- BA-CH Basic Arm Cymbal Holder
- BA-PA Basic Arm Percussion Adapter
- BA-TB Basic Arm Tele Boom, 550 mm

- BR12 MC
- BA12-L
- BA12-S
- BA12-BR

- BA-TB
- BA-CH
- BA-PA

Basic Arm 12

- BR12-MC Basic Rack, with Arm 485 mm
- BA12-S Basic Arm 12, short, 285 mm
- BA12-L Basic Arm 12, long, 485 mm
- BA12-BR Basic Arm 12 Basic Ratchet

600 Hardware X-Hat

- XH 674 X-Hat with adjustable spring tension, 7-step bottom cymbal tilter



Basic Arm 19

- BA19-S MC Basic Arm 19, short, 150 mm
- BA19-M MC Basic Arm 19, medium, 220 mm
- BA19-BR Basic Arm 19 Basic Ratchet
- BA19-BSS MC Basic Arm 19 Single Stand
- BA19-BDS MC Basic Arm 19 Double Stand

BA19-BDS MC, 4x BA 19S MC, 2x wing screw & bolt (item no. 190 235 01)

Did you know?

You can simply build a classic tom holder with our Basic Arm program to fit older SONOR Series like Signature, Phonic, Performer and Force 2000 and 3000 Series!



Multi Holder

NEW

Our new Multi Holder line features rubber inserts on the inside of each clamp to avoid dents and scratches on your hardware. The new clamps are compatible with our Basic Arm System for endless options and individual set-up solutions.

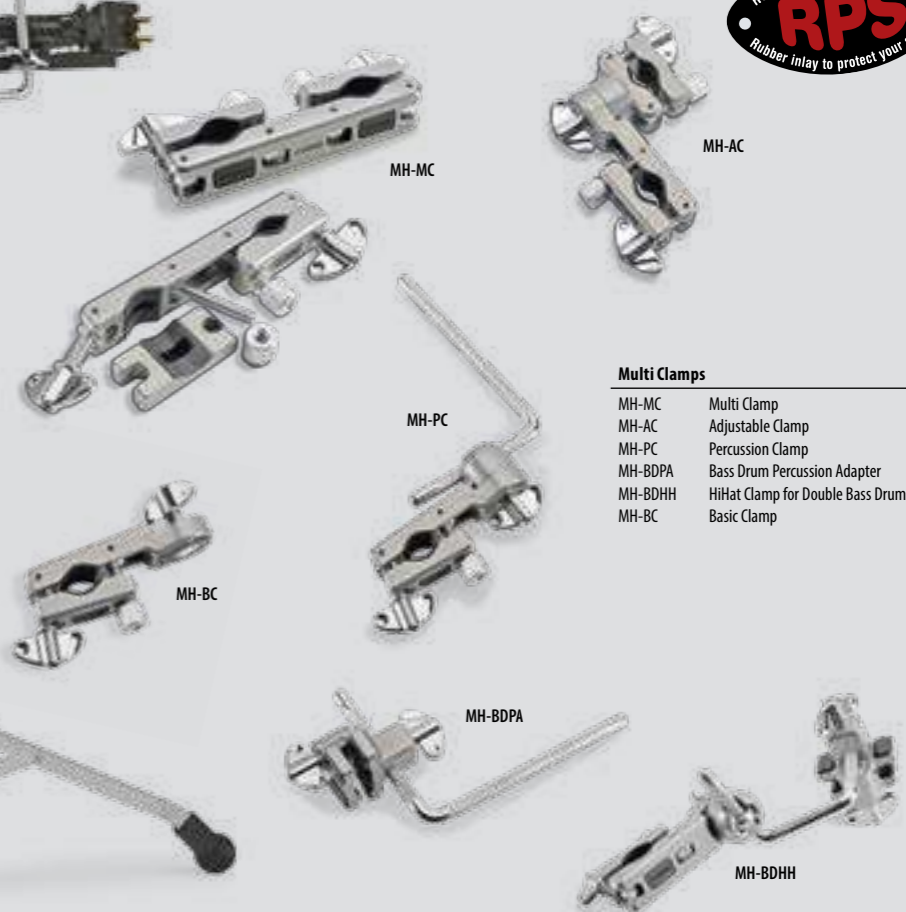

Multi Clamps

- MH-MC Multi Clamp
- MH-AC Adjustable Clamp
- MH-PC Percussion Clamp
- MH-BDPA Bass Drum Percussion Adapter
- MH-BDHH HiHat Clamp for Double Bass Drum
- MH-BC Basic Clamp



MH-BC, XH 674, BA19-S MC, MH-AC

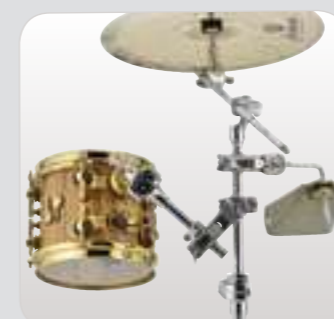

MH-AC, TA 678 MC, MH-PC



MH-BDHH



MH-BDPA

Tom Holder

600 Hardware Tom Holders

- DTH 675MC Double Tom Holder with 2 tom arms with ball clamp²
- STH 674 MC Single Tom Holder with 3-section clamp and tom arm with ball clamp²
- TA 678 MC Tom Arm with ball clamp²

4000 Hardware Tom Holders

- DTH 4000 Double Tom Holder with 2 tom arms with ball clamp²
- STH 4000 Single Tom Holder with 2-section clamp and tom arm with ball clamp²
- TA 4000 Tom Arm with ball clamp²

2000 Hardware Tom Holders

- DTH 2000 Double Tom Holder with ball clamp²



DTH 675 MC



TA 678 MC



STH 674 MC



DTH 4000

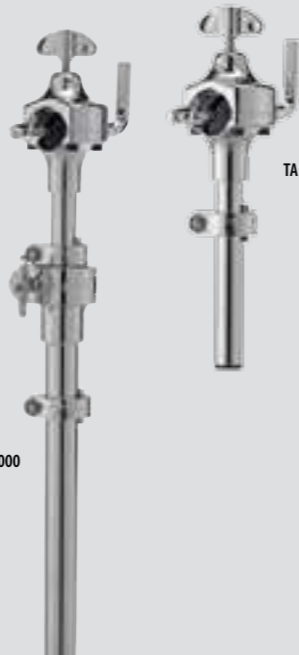

STH 4000



TA 4000



DTH 2000

Vintage Series Tom Holders **NEW**

- STH-VT 674 MC Single Tom Holder with Vintage Series screws and tom arm with ball clamp²
- DTH-VT 675 MC Double Tom Holder with Vintage Series screws and tom arm with ball clamp²



STH-VT 674 MC



DTH-VT 675 MC

²) DE pat. 43 33 913 / GB pat. 2 273 043 / US pat. 5.803.642

Hardware Sets

HS 400 Hardware Set

- consisting of:
- HH 400 Hi-Hat Stand
 - SS 4000 Snare Drum Stand
 - MBS 4000 Mini Boom Stand (2x)
 - SP 473 Bass Drum Single Pedal



HS XS 200 Hardware Set

- consisting of:
- HH XS 200 Hi-Hat Stand, extra low
 - SS XS 2000 Snare Drum Stand, extra low
 - MBS 2000 V2 Mini Boom Stand (2x)
 - SP 473 Bass Drum Single Pedal



HS 200 Hardware Set

- consisting of:
- HH 200 Hi-Hat Stand
 - SS 2000 Snare Drum Stand
 - MBS 2000 V2 Mini Boom Stand (2x)
 - SP 473 Bass Drum Single Pedal

Accessories

Often, it's the little things that make the difference. SONOR Accessories cover all of the important and useful accessories and replacement parts you'll ever need.

SONOR Accessories

- CC 5215 Cymbal Clamp, plastic, single unit for M6 threads
- CC 5215/6 Cymbal Clamp, plastic, six pack for M6 threads
- PP 9300 Practice Pad for 14" Snare Drum, rubber
- SL 5205 Super Lock Tuning Safe Set, 20 pieces
- BDE 16"/18" Bass Drum Elevation with spurs extension, Prism Clamp with drilling template, Jungle adapter

Bass Drum Beaters

- SCH 20 Bass Drum felt head beater with conical shape
- SCH 28 Two Way Beater, with two playing surfaces: felt and plastic

Memory Locks

- ML-R for Bass Drum spur right
- ML-L for Bass Drum spur left
- ML-VT for Vintage Series Bass Drum spurs and Tom Tom mounts

Tuning Keys

- PTK „Protean“ Tuning Key (square head rods)
- RK Rotor Key incl. clip and key ring (square head rods / slotted rods as from the year 2006)
- MTK Multi Tuning Key (square/Allen head rods SW 4)
- MK Multi Key (square head/slotted metric rods)
- DK 5072 Tuning Key, short (slotted rods)

3-Section Memory Clamps

with plastic inlay to protect the tube surface available for
19.1 mm tube diameter
25.4 mm tube diameter
28.5 mm tube diameter



Soundwires

High quality snare wires Made in Germany

SoundWire is SONOR's answer to any drummer looking for new ways to enhance their snare drum sound. With 3 different materials (steel, brass and bronze) and multiple snare wire variations plus the mounting options of string or strap, SoundWire offers almost unlimited sonic choices.

SONOR SoundWire snares feature specially designed end plates that ensure perfect snares-to-head contact. Rounded plate edges prevent head damage during snare tightening. Each set of snares comes in an attractive wood box that ensures best protection.



- ### Steel Snare Wires
- SW 1218 S for 12", 18 Wires ø 0.5 mm
 - SW 1318 S for 13", 18 Wires ø 0.5 mm
 - SW 1418 S for 14", 18 Wires ø 0.5 mm
 - SW 1424 S for 14", 24 Wires ø 0.5 mm

- ### Bronze Snare Wires
- SW 1018 B for 10", 18 Wires ø 0.5 mm
 - SW 1418 B for 14", 18 Wires ø 0.5 mm
 - SW 1424 B for 14", 24 Wires ø 0.5 mm

- ### Brass Snare Wires
- SW 1418 MS 05 for 14", 18 Wires ø 0.5 mm
 - SW 1424 MS 05 for 14", 24 Wires ø 0.5 mm

Tambourine

In combination with the TH Holder our light-weight Tambourines can easily be mounted to any stand to expand the sonical possibilities of your kit. These are available in the choice of steel or brass bells and both in black or white finish.

- TBBJ Tambourine, black with brass bells
- TBSJ Tambourine, black with steel bells
- TH Tambourine Holder
- TWBJ Tambourine, white with brass bells
- TWSJ Tambourine, white with steel bells

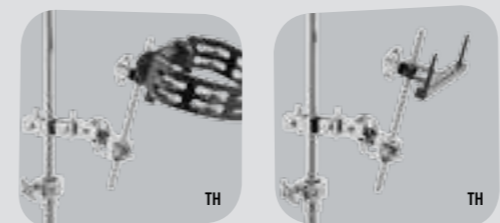

Cowbells

The special three-side wing screw offers ultimate mounting comfort even in extended configurations. Our brass cowbells are available in four different sizes and deliver a warm and full bodied sound.

- CB 4 Charanga Bell 4", Brass
- CCB 55 Cha-Cha Bell 5 1/2", Brass
- CCB 5 Cha-Cha Bell 5", Brass
- MB 8 Mambo Bell 8", Brass

Dual Glide Snare Strainer Mechanism



The strainer mechanism features a technically perfected snare wire engage-and-release system, along with great adjustability and a solid look and feel. "DUAL GLIDE SYSTEM" refers to the precise and smooth action, which in turn eliminates any un-wanted sounds when the snare wires are placed in "on" or "off" position. Both the strainer and butt sides are equipped with a fast-release snare wire detach function, allowing the drummer to change the resonant head without having to loosen and adjust the Snare wires. A fine-tune adjustment knob is employed on both sides.

Thanks to the well thought-out design and construction, the new Dual Glide strainer also works to replace the current strainer on most of SONOR's snare drums, and is available as an individual component.



Dual Glide Snare Strainer

- DGS SC Dual Glide Snare Strainer, chrome-plated, single unit
- DGS BC Dual Glide Butt End, chrome-plated, single unit
- DGS SB Dual Glide Snare Strainer, black-plated, single unit
- DGS BB Dual Glide Butt End, black-plated, single unit
- DGS SG Dual Glide Snare Strainer, gold-plated, single unit
- DGS BG Dual Glide Butt End, gold-plated, single unit

Drumheads

Power Black - Front Head/SONOR Logo

- Edge ring, black, single ply, medium
- PB 18 B/L = 18" PB 22 B/L = 22"
- PB 20 B/L = 20" PB 24 B/L = 24"

Power White - Front Head/SONOR Logo

- Edge ring, white, coated, single ply, medium
- PW 18 B/L = 18" PW 22 B/L = 22"
- PW 20 B/L = 20" PW 24 B/L = 24"

Vintage Natural - Front Head/SONOR Vintage Logo

- Edge Ring, natural, single ply, medium
- NP 18 B/L = 18" NP 22 B/L = 22"
- NP 20 B/L = 20" NP 24 B/L = 24"



Bags

Global Bags for Snare Drums

- GB S 1405 Bag for a 14" x 5.5" Snare Drum
- GB S 1406 Bag for a 14" x 6.5" Snare Drum

Global Bag for Cymbals

- GB C 22 Bag for Cymbals up to 22"

SONOR Stick Bag

- SSB Stick Bag, professional version

GB S 1405 / GB S 1406

All hand-hammered Armoni Cymbals, made exclusively for SONOR by a traditional Turkish Cymbal company, are of B20 Bronze (a mix of 80% Copper and 20% Tin). The total production process is comprised of traditional handcrafted methods.



After melting and tempering the B20 Bronze, the material is rolled into discs and multiple pressed as the raw cymbal afterwards. Then the cymbals are hand hammered, lathed and polished.

Armoni Sounds

Our Armoni Cymbals deliver fast, lightening-bright sounds and modern response for today's musical styles. Every drummer looking for new and modern Cymbals will find the perfect sound in our Cymbal line.



AC 14 HH



AC 13 HH



AC 22 R

AC 20 R



AC SET 1

AC SET 1 Armoni Cymbal Set 1
AC 14 HH 14" Hi-Hat Cymbal, brilliant
AC 16 C 16" Crash Cymbal, brilliant
AC 20 R 20" Ride Cymbal, brilliant
incl. Cymbal Bag

Armoni Series Cymbals
AC 13 HH 13" Hi-Hat Cymbal, brilliant
AC 14 HH 14" Hi-Hat Cymbal, brilliant
AC 14 C 14" Crash Cymbal, brilliant
AC 15 C 15" Crash Cymbal, brilliant
AC 16 C 16" Crash Cymbal, brilliant
AC 17 C 17" Crash Cymbal, brilliant
AC 18 C 18" Crash Cymbal, brilliant
AC 19 C 19" Crash Cymbal, brilliant
AC 20 R 20" Ride Cymbal, brilliant
AC 22 R 22" Ride Cymbal, brilliant
AC 08 S 8" Splash Cymbal, brilliant
AC 10 S 10" Splash Cymbal, brilliant
AC 12 S 12" Splash Cymbal, brilliant
AC 14 CH 14" China Cymbal, brilliant
AC 16 CH 16" China Cymbal, brilliant
AC 18 CH 18" China Cymbal, brilliant



AC 14 C

AC 18 C

AC 16 C



AC 18 CH

AC 14 CH

AC 16 CH



AC 15 C

AC 17 C

AC 19 C

sonor.com

